

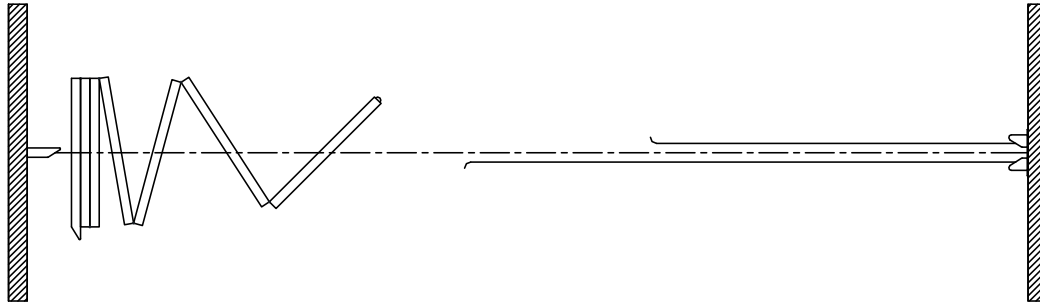

MODERCO

Excel 700 Series

Technical Data Sheet Excel 733-EG



Features & Options

Standard Features

- Electrically-operated continuously-hinged movable partition.
- Driven with Ø5 mm [3/16"] steel cable.
- STC 43 or 49.
- 76 mm [3"] nominal thickness. 1230 mm [48 1/2"] maximum width.
- 18 ga. welded steel frame.
- Roll-formed steel faces welded to panel frame.
- Panel core made up of one 25 mm [1"] semi-rigid insulation board between two 25 mm [1"] honeycomb boards.
- Trimless vertical edges.
- Vinyl tongue and groove vertical sound seals between panels.
- Final closure at wall jamb.
- Continuous-contact multi-finger fixed vinyl top seals.
- Continuous-contact multi-finger adjustable vinyl bottom seals.
- Steel butt hinges.

- S5X10 steel track.
- Odd-numbered panels supported by one 4-wheeled carrier with steel tires over sealed steel ball bearing wheels.
- Vinyl wallcovering.
- Maximum height: 9220 mm [30'-3"].
- UL/ULC listed drive unit with NEMA-1 motor enclosure and controls and control enclosure conform to ANSI/NEMA ICS1, ICS 2 and ICS 6..
- 1.5 hp / 208 V / 3 ph / 60 Hz
- Travel controlled by limit switches.
- Operation by two simultaneously-activated key switches located on each side of the partition.

Optional Features and Accessories

- Final closure at pocket door.
- Powder-coated frame and/or track.
- Vertically-ribbed carpet wallcovering.
- Owner-supplied wallcovering (approval required).
- ADA-compliant pass door with flush pulls and roller latch.

Optional Features and Accessories (cont'd)

- Door options:
 - concealed automatic closer
 - window frame
 - door viewer
 - self-illuminated exit sign *
 - “green running man” self-illuminated exit sign *
 - deadbolt lock *
 (* An exit sign and a deadbolt lock will not be installed together on the same door.)
- Surface-mounted white marker boards.
- Surface-mounted chalk boards.
- Surface-mounted natural cork tack boards.
- 3-section pocket door fitted with limit switches to prevent operation of the partition until the pocket door is fully opened.
- Drive unit voltage:
 - 1ph – 120 V / 240 V (up to 25 panels)
 - 3 ph – 230 V / 460 V / 575 V
- Safety devices:
 - Infra-red photo-electric sensors prevent/stop operation if one of the beams is interrupted
 - Safety mats in stack area prevent/stop operation if a mass is detected
 - Safety lead edge stops operation is it meets an obstacle
- Operation by one key switch and one push button switch.

Horizontal Seals

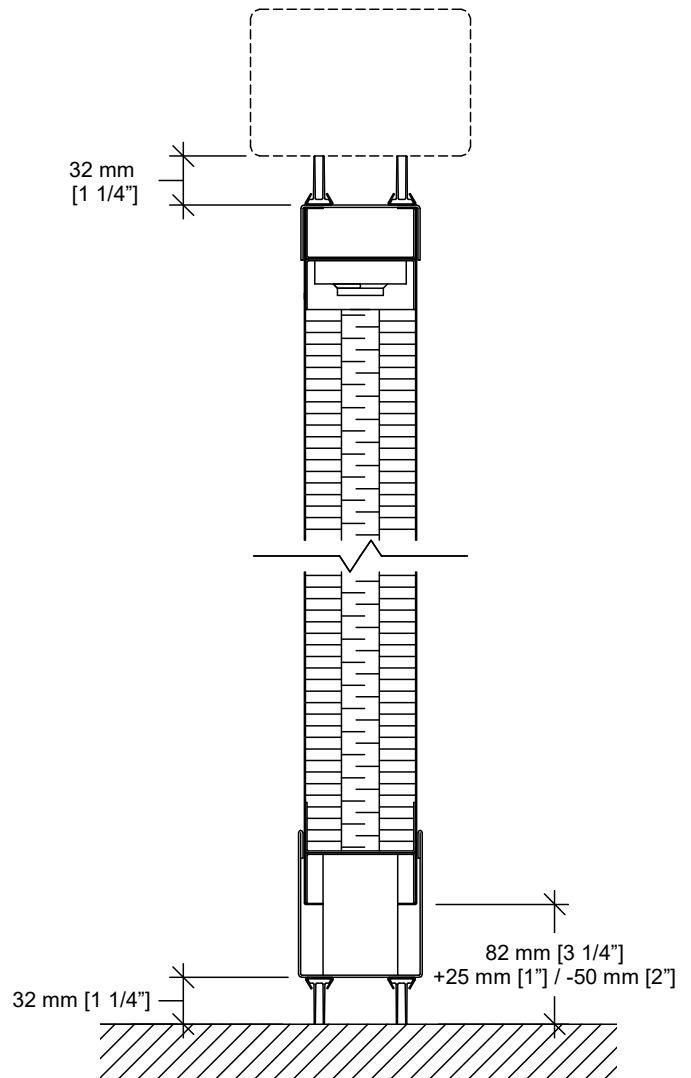

Floor clearance : 32 mm [1 1/4"]
 Operating tolerances :
 +25 mm / -50 mm [+1" / -2"]



MODERCO

Vertical Section

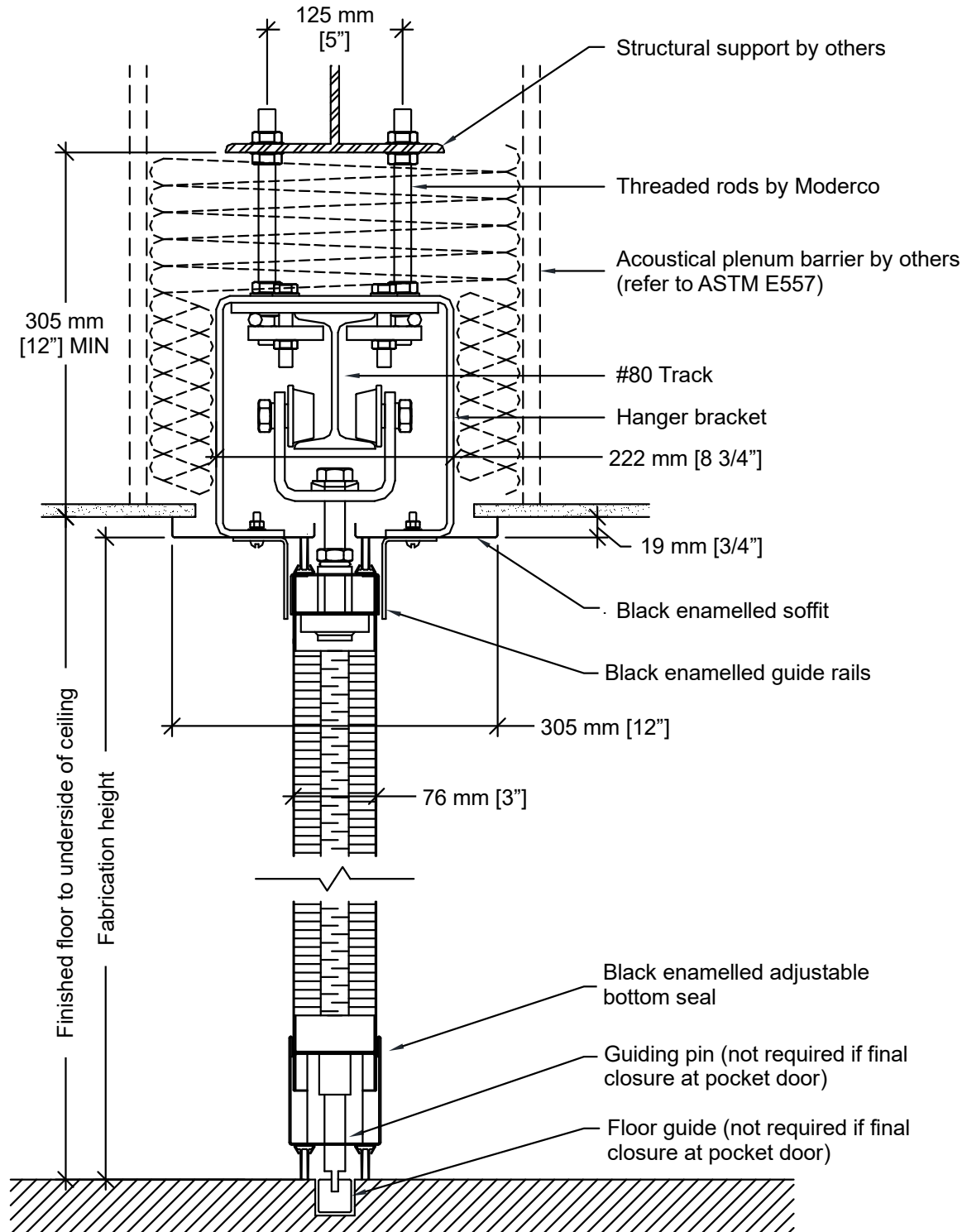

Elevation

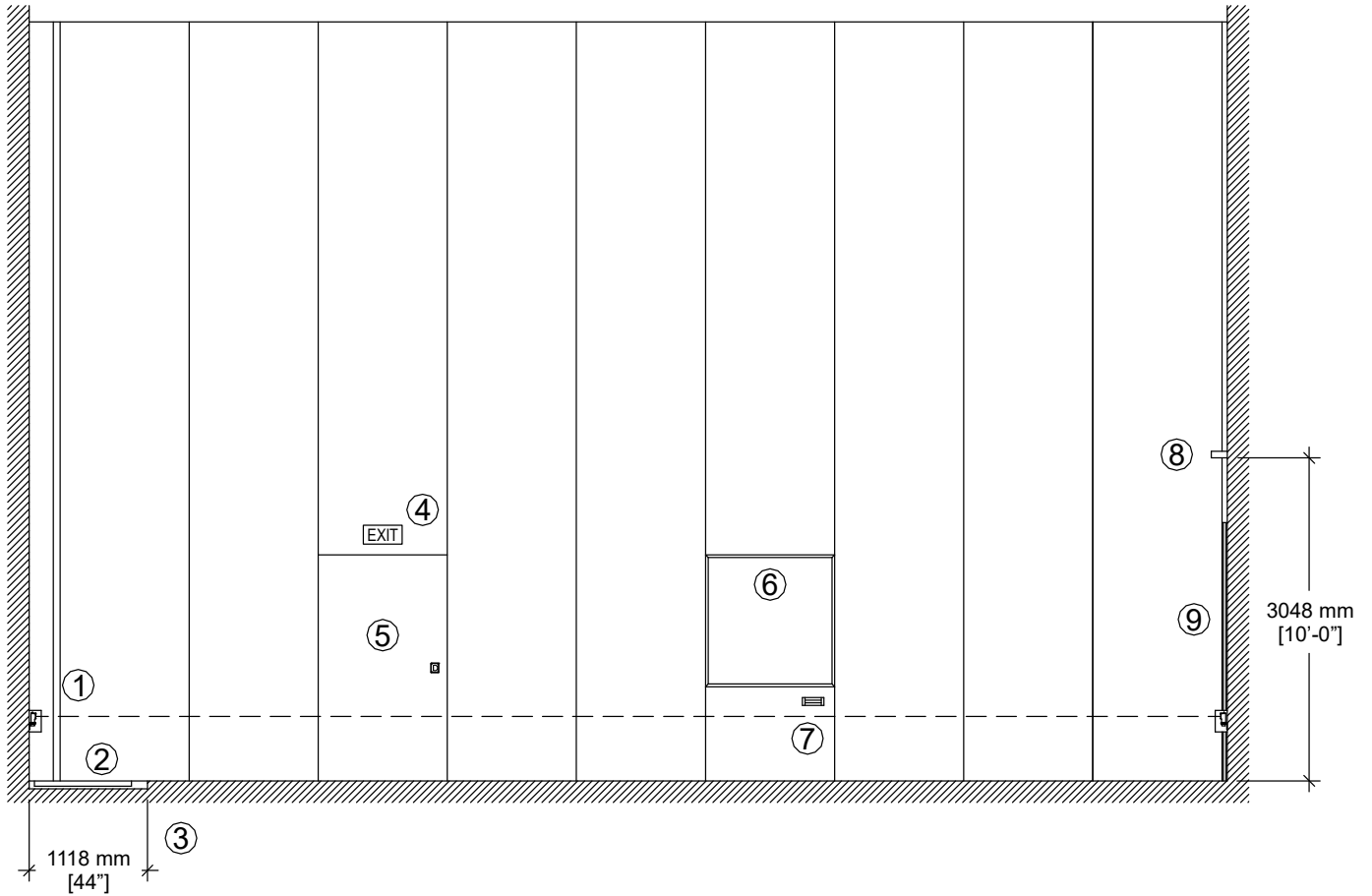

1- Infra-red photo-electric sensors

2- Safety mats

3- Floor guide (not required if final closure at pocket door)

4- Exit sign

5- Passdoor

6- Work surface

7- Eraser box

8- Lead-in bracket

9- Safety lead edge

Plan Views

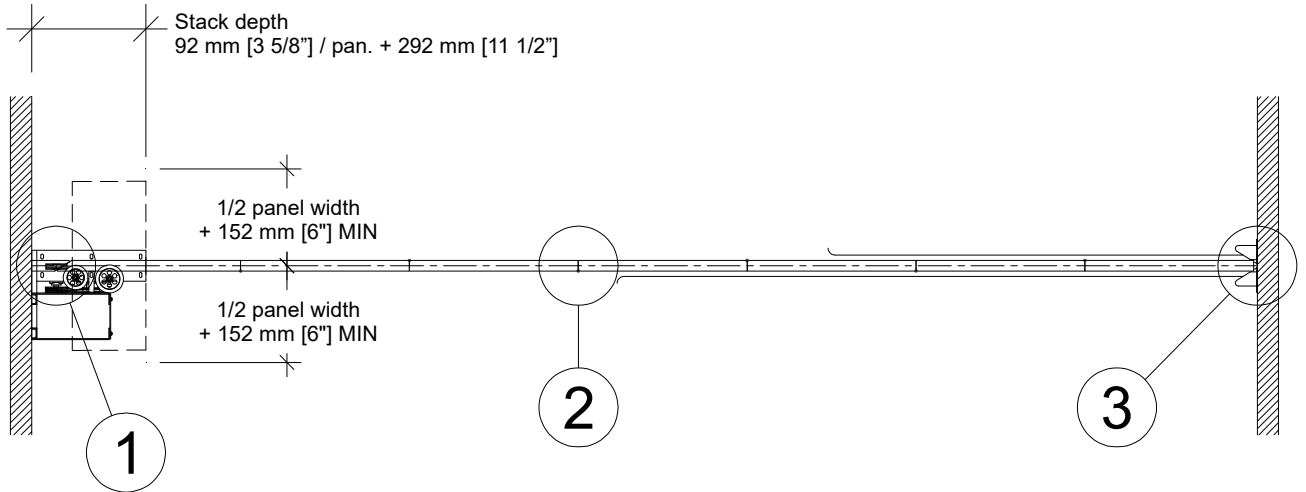

Final closure at wall jamb

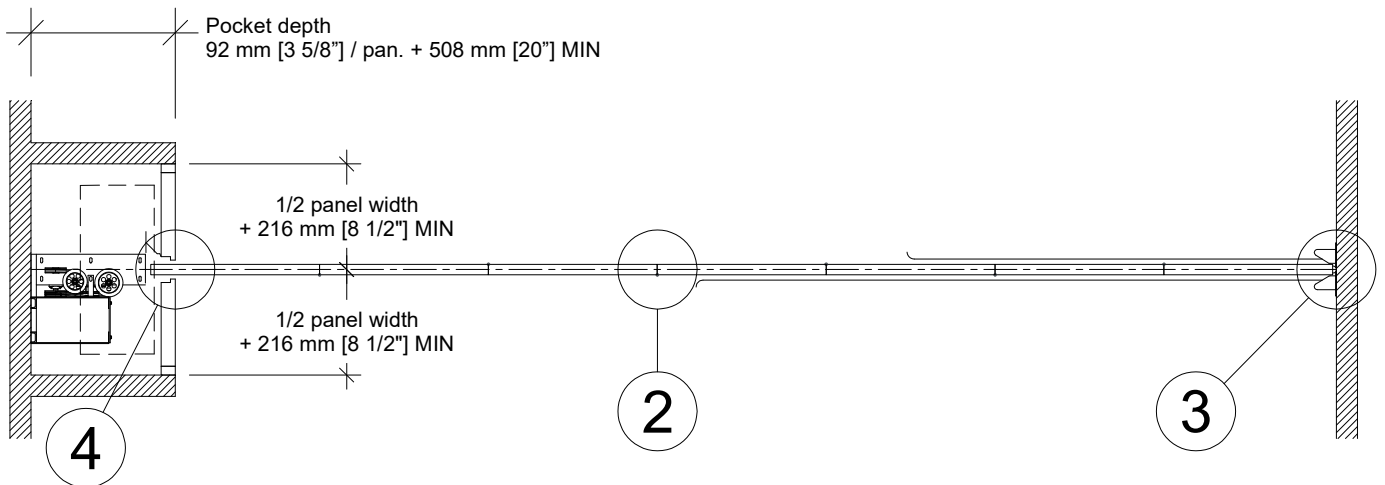

Final closure at optional pocket door

Horizontal Sections

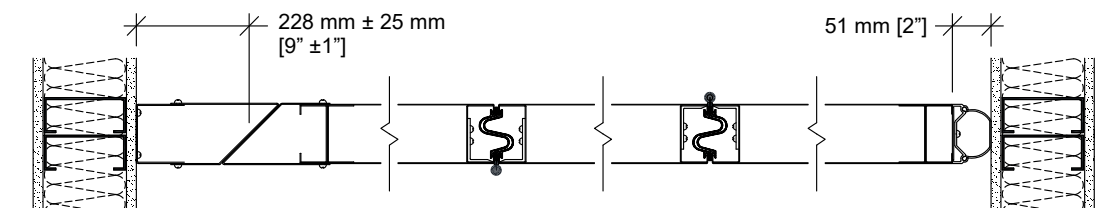

Solid blocking
by others

Solid blocking
by others

① Wall jamb

② Panel joint

③ Bulb seal

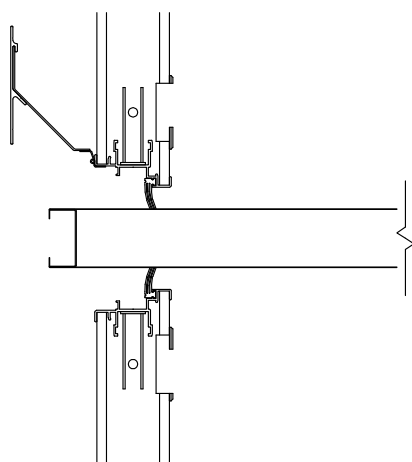

④ Pocket door
(optional)

Drive Unit

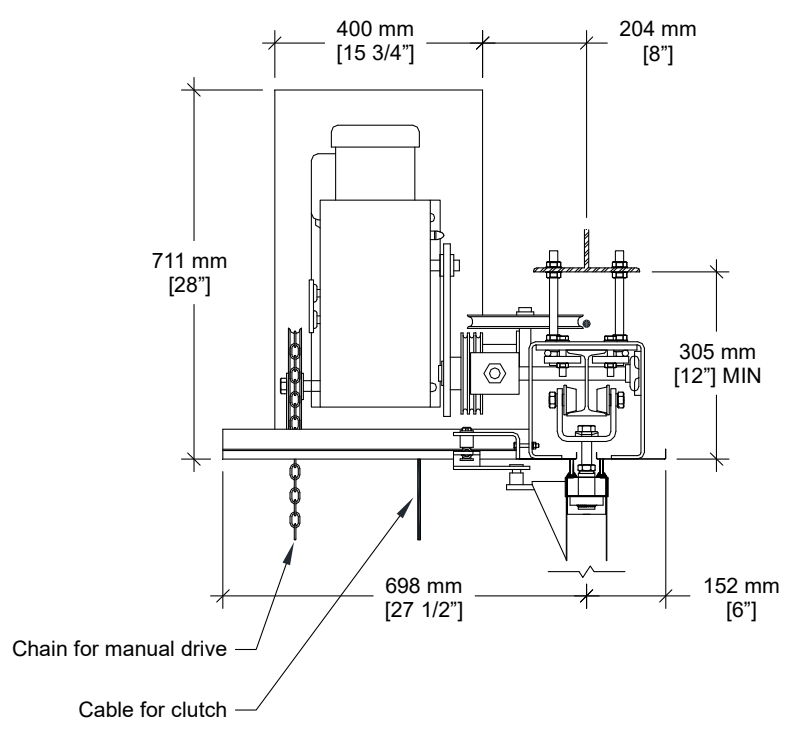

Optional Safety Devices

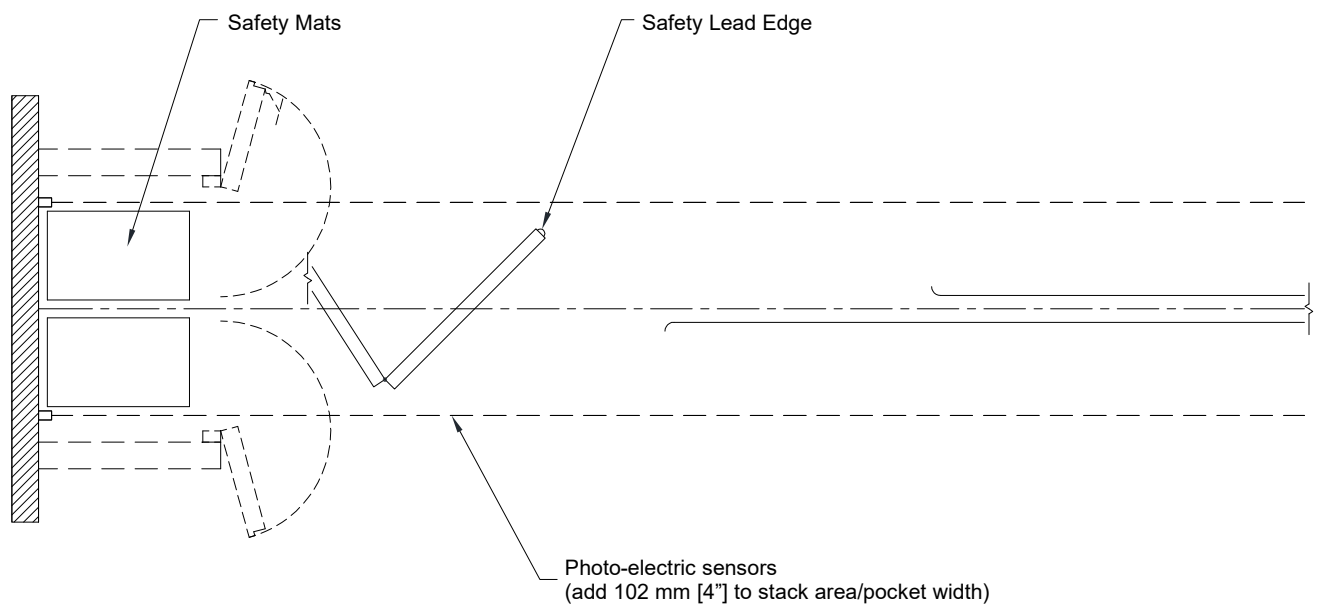

Pocket Door

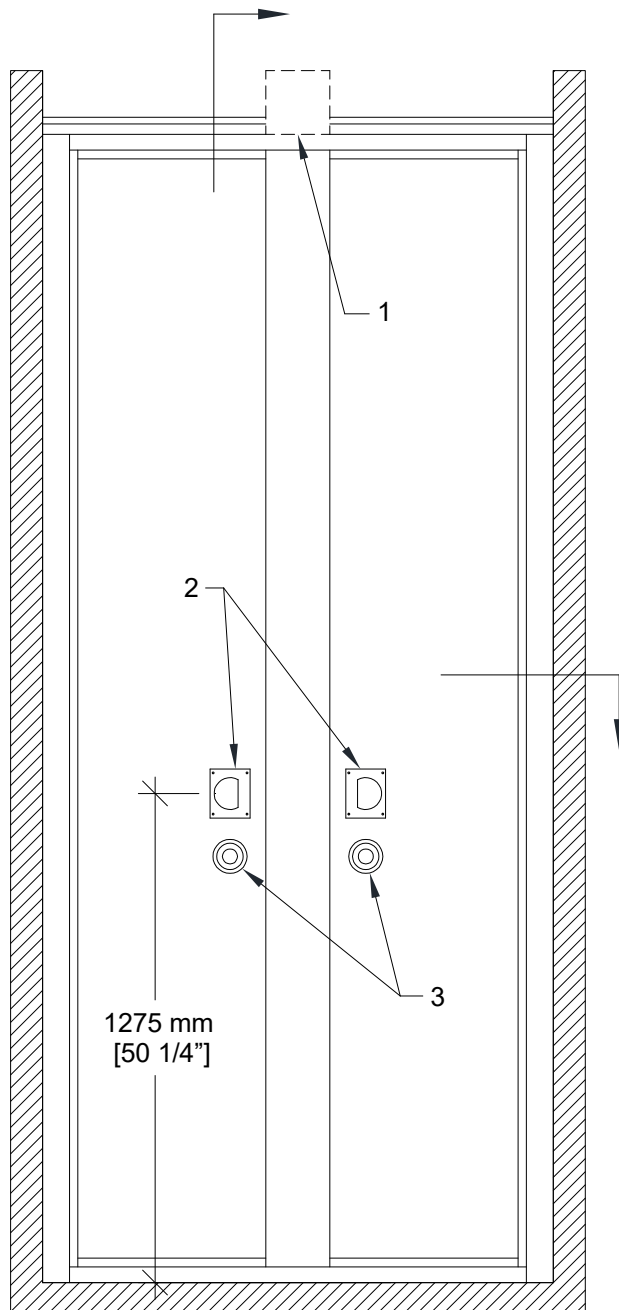

General

- 2 independent sections and 1 center flap
- Same surface finish as movable partition / optional custom finish / unfinished
- Clear anodized frame / optional custom finish
- Top and bottom locking bolts
- Low profile hinges

PN-73G Non-acoustical Pocket Door

- Optional for wall-to-wall layout

PA-73G Acoustical Pocket Door

- Fixed top and bottom sweeps
- Required for wall-to-pocket layout

- 1- Track
- 2- Flush pulls
- 3- Locking bolt activators

Vertical Section

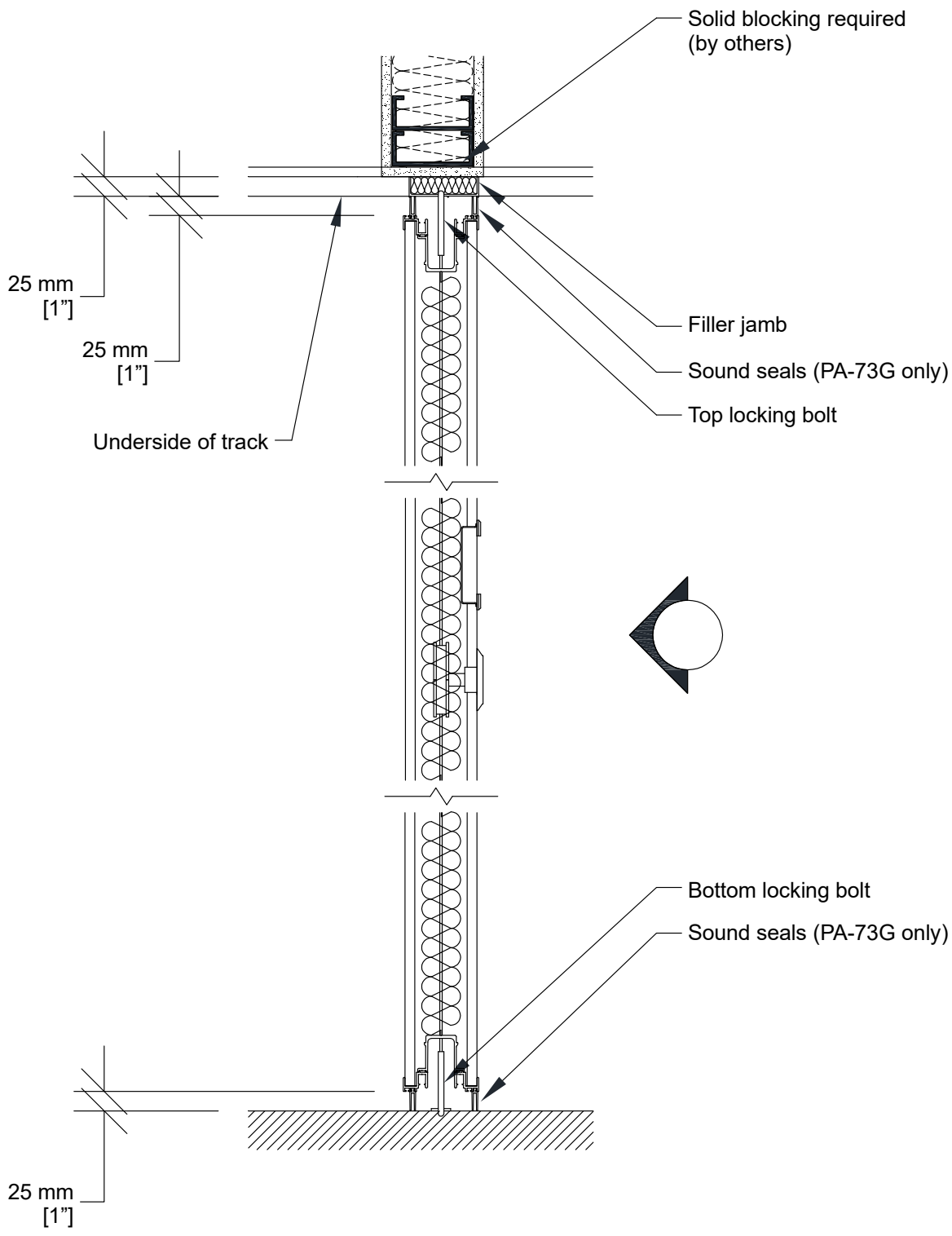

Horizontal Section

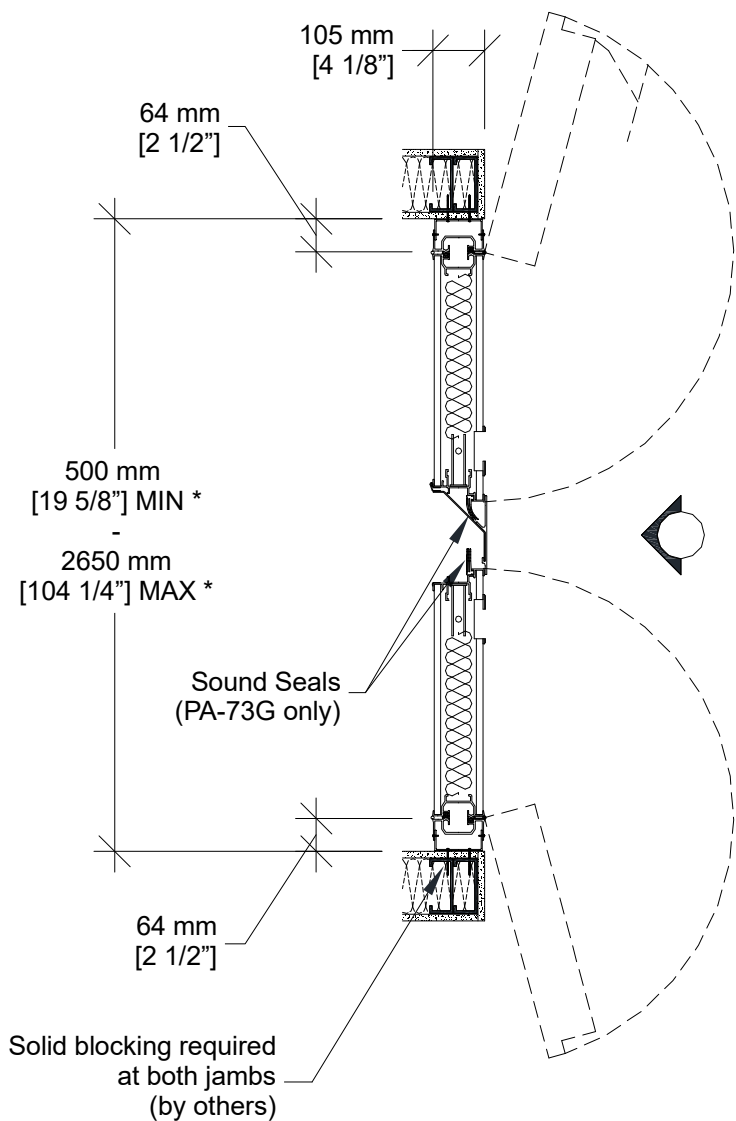

* Min/Max dimensions are fabrication limits and do not account for job-specific conditions.

Please consult shop drawings or local Moderco distributor prior to sizing pockets.