

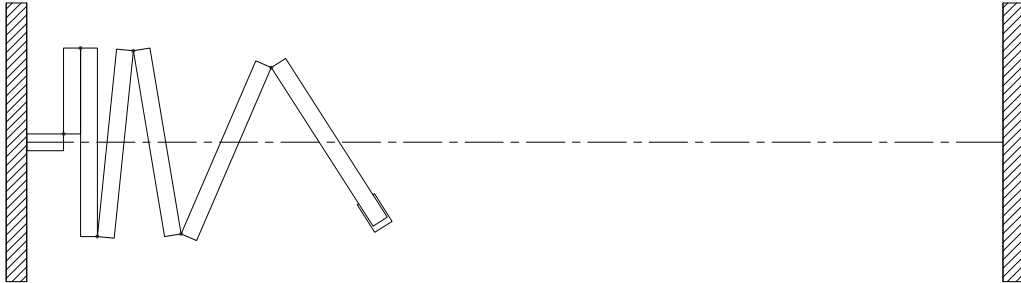

MODERCO

Signature 8000 Series

Technical Data Sheet 8760



Features & Options

Standard Features

- Electrically-operated continuously-hinged movable partition.
- Driven with Ø5 mm [3/16"] steel cable.
- STC 43 or 47 with gypsum board faces.
- STC 49, 52 or 53 with steel faces laminated to gypsum board.
- 102 mm [4"] nominal thickness. 1230 mm [48 1/2"] maximum width.
- Clear-anodized steel-reinforced aluminum frame.
- Protective trims on entire perimeter.
- Combination aluminum and vinyl tongue and groove vertical sound seals between panels.
- Final closure by pneumatically-operated telescopic mechanism.
- Type FP horizontal seals :
 - Fixed top sweeps
 - Pneumatically-operated bottom seals
 - bottom seals provide a 50 mm [2"] floor clearance
- Low profile steel hinges.
- Clear-anodized 6063-T6 alloy aluminum track.

- Each panel supported by one 4-wheeled carrier with steel tires over hardened steel ball bearing wheels.
- Vinyl wallcovering.
- Maximum height: 6780 mm [22'-3"]
Maximum length: 24385 mm [80'-0"]
- UL/ULC listed drive unit with NEMA-1 motor enclosure and controls and control enclosure conform to ANSI/NEMA ICS1, ICS 2 and ICS 6.
- 1.5 hp / 120 V / 1 ph / 60 Hz drive unit
- 0.5 hp / 110 V / 40 dB CSA listed compressor (existing building air line system may be used, 115 psi MIN)
- Travel controlled by limit switches.
- Operation by two simultaneously-activated key switches located on each side of the partition.

Optional Features and Accessories

- STC 49, 52 or 53 with gypsum board faces and steel backing.
- Powder-coated protective trims and/or track.
- Upgraded wallcoverings : fabric, vertically-ribbed carpet, or full-height marker board.
- Owner-supplied wallcovering (approval required).

Optional Features and Accessories (cont'd)

- ADA-compliant pass door with flush pulls and roller latch.
- Door options:
 - concealed automatic closer
 - window frame
 - door viewer
 - self-illuminated exit sign *
 - “green running man” self-illuminated exit sign *
 - deadbolt lock *
 (* An exit sign and a deadbolt lock will not be installed together on the same door.)
- Inset white marker boards.
- Inset chalk boards.
- Inset natural cork tack boards.
- Eraser boxes.
- 3-section pocket door fitted with limit switches to prevent operation of the partition until the pocket door is fully opened.

Horizontal Seals

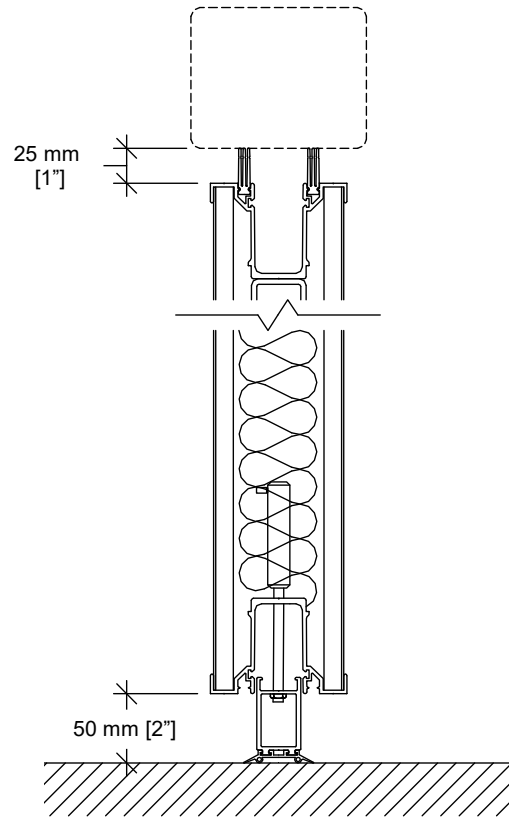

Type FP

Floor clearance : 50 mm [2"]
 Operating tolerances :
 +0 mm / -38 mm [+0" / -1 1/2"]

Vertical Section

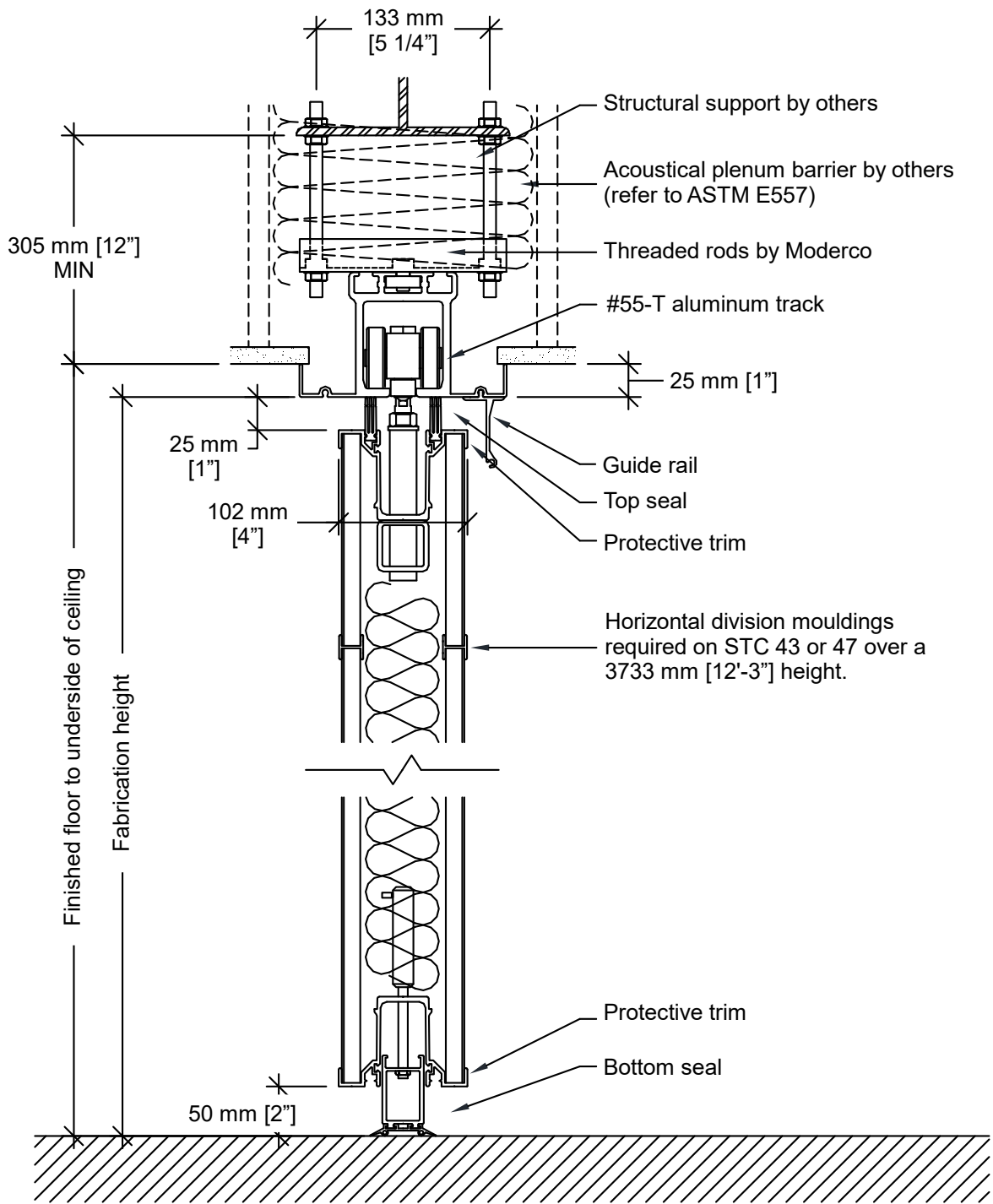

Plan Views

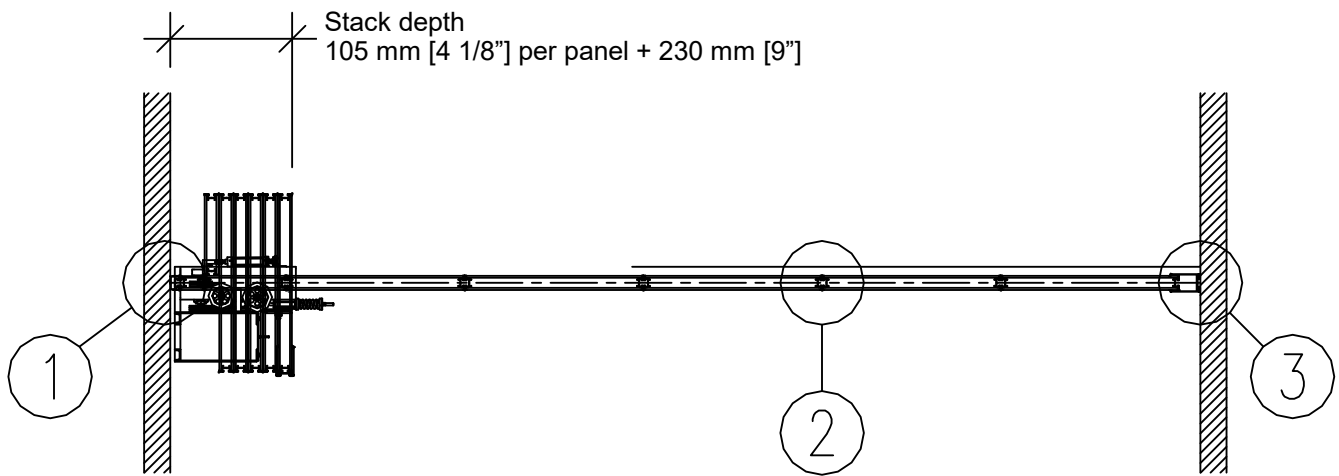

Wall to wall

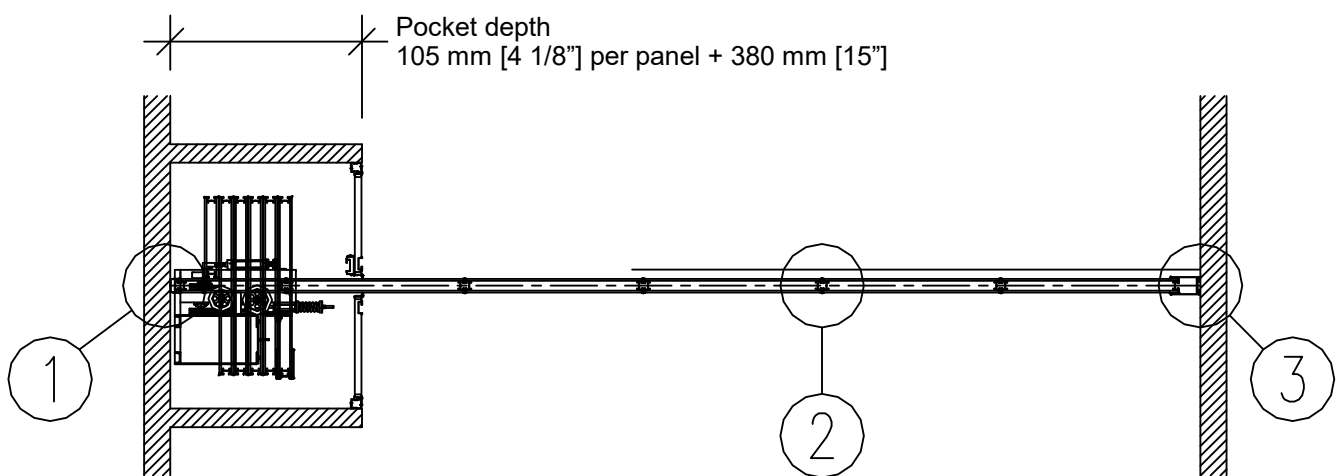

Wall to wall with pocket door

Horizontal Section

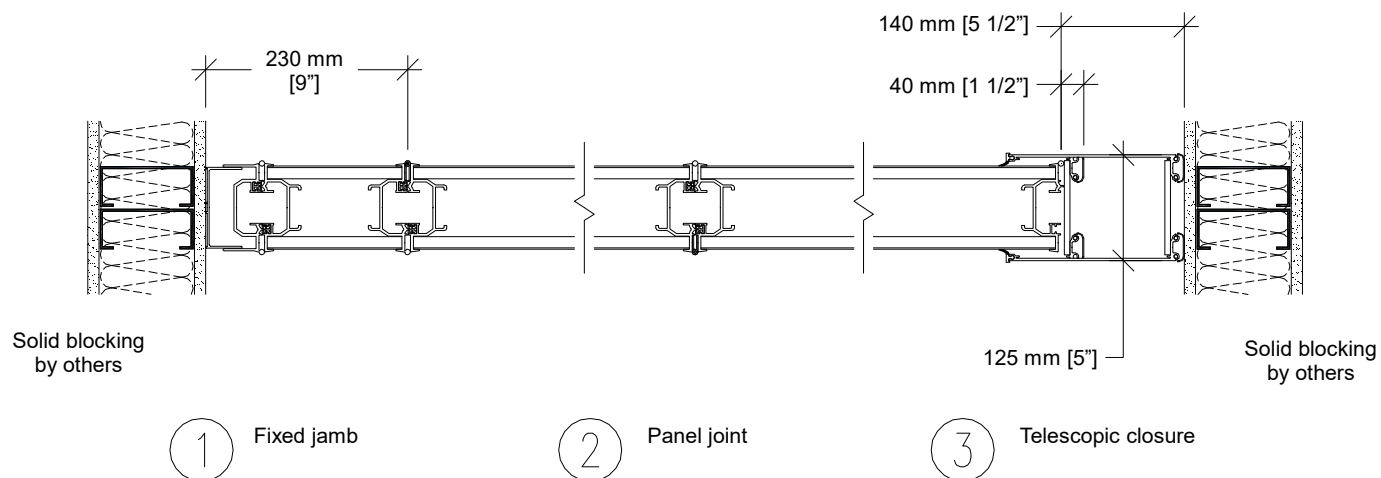

Elevation

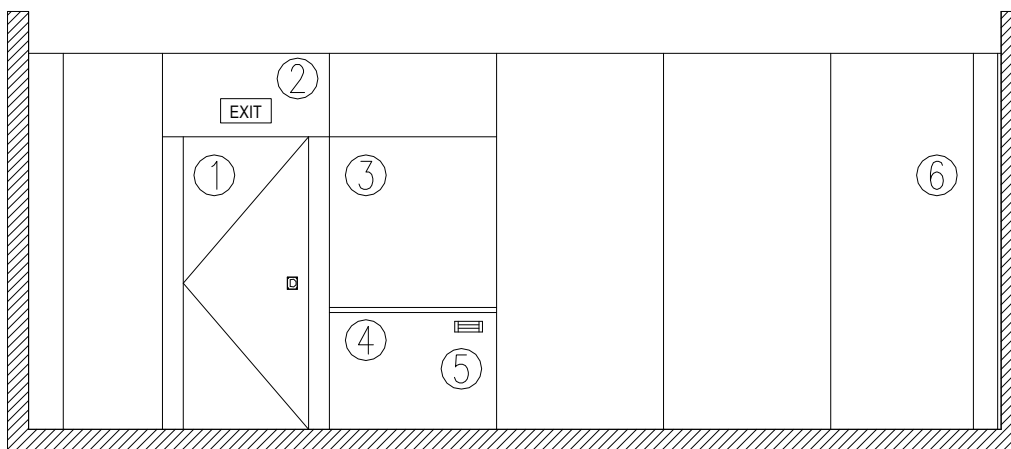

- | | |
|-------------------------------|------------------|
| 1- Single pass door | 4- Chalk tray |
| 2- Self-illuminated exit sign | 5- Eraser box |
| 3- Work surface | 6- Closure panel |

Drive Unit

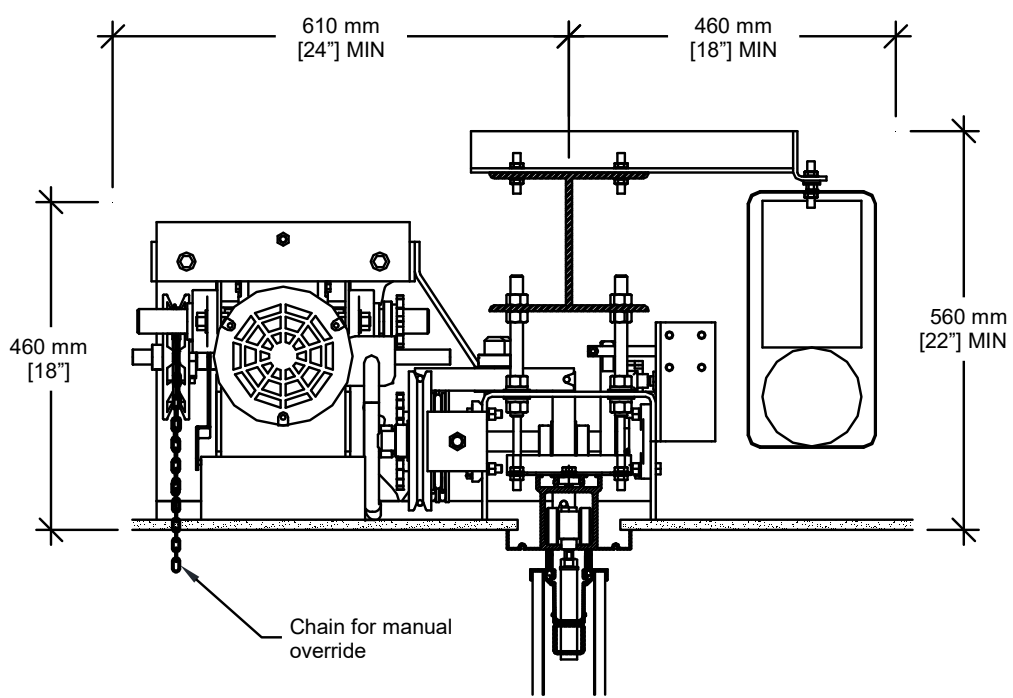

Compressor installed on top of beam

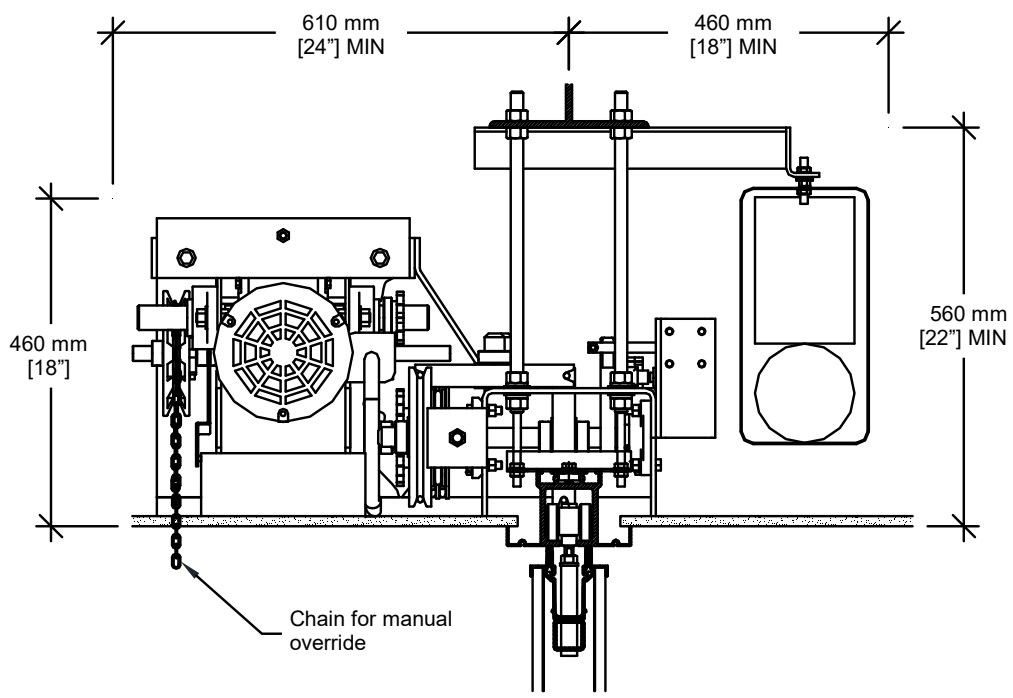

Compressor installed under beam

Safety Devices

