

Technical Data Sheet Signature 8600

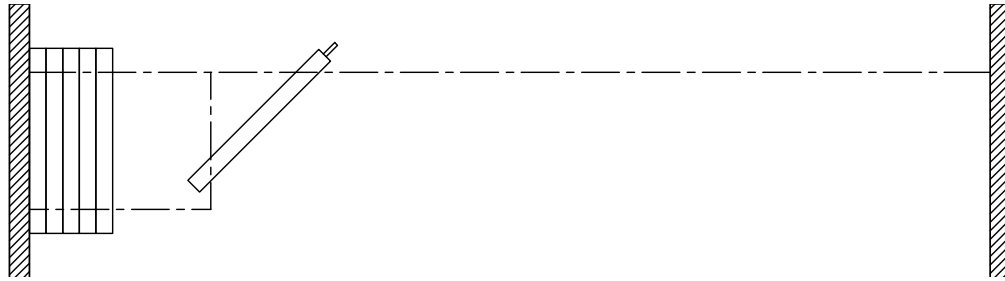

Features & Options

Standard Features

- Manually-operated individual-panel movable partition.
- STC 43 or 47 with gypsum board faces.
- STC 49, 52, 53, or 55 with steel faces laminated to gypsum board.
- 102 mm [4"] nominal thickness. 1230 mm [48 1/2"] maximum width.
- Clear-anodized steel-reinforced aluminum frame.
- Protective trims on entire perimeter.
- Combination aluminum and vinyl tongue and groove vertical sound seals between panels.
- Final closure by telescopic jamb.
- Type FA horizontal seals:
 - Fixed top sweeps
 - Automatic retractable bottom seals set as panels are deployed
 - bottom seals provide a 50 mm [2"] floor clearance
- (STC 53) Type MM-1 horizontal seals:
 - top and bottom retractable seals
 - Manually-operated, simultaneously-activated top and bottom seals
 - bottom seals provide a 25 mm [1"] floor clearance

- (STC 55) Type MM-55 horizontal seals:
 - top and bottom retractable seals
 - Manually-operated, simultaneously-activated top and bottom seals
 - bottom seals provide a 25 mm [1"] floor clearance
 - additional fixed top sweeps
- Clear-anodized 6063-T6 alloy aluminum track.
- Each panel supported by two carriers made up of two horizontally-aligned precision-ground hardened steel ball bearing wheels with nylon tires.
- Vinyl wallcovering.

Optional Features and Accessories

- STC 49, 52, 53, or 55 with gypsum board faces and steel backing.
- Trimless vertical edges.
- Powder-coated frame and/or track.
- 11 ga. steel track, painted white.
- Upgraded wallcoverings : fabric, vertically-ribbed carpet, plastic laminate, full-height marker board, wood veneer, custom finishes.
- Owner-supplied wallcovering (approval required).
- Final closure by hinged closure panel.

Optional Features and Accessories (cont'd)

- (STC 43 to 52) Type FM horizontal seals:
 - Fixed top sweeps
 - Manually-operated bottom seals
 - bottom seals provide a floor clearance of 25 mm [1"], 38 mm [1 1/2"], 50 mm [2"], 64 mm [2 1/2"], or 102 mm [4"]
- (STC 43 to 52) Type MM horizontal seals:
 - top and bottom retractable seals
 - Manually-operated, simultaneously-activated top and bottom seals
 - bottom seals provide a floor clearance of 25 mm [1"], 38 mm [1 1/2"], 50 mm [2"], 64 mm [2 1/2"], or 102 mm [4"]
- (STC 43 to 52) Type AA horizontal seals:
 - top and bottom retractable seals
 - simultaneously-activated Automatic top and bottom seals
 - bottom seals provide a floor clearance of 38 mm [1 1/2"]
 - simultaneous operation of telescopic closure and seals of last panel (also available on partitions with type MM-1.5 horizontal seals)
- ADA-compliant pass door with flush pulls and roller latch.
- Door options:
 - concealed automatic closer
 - window frame
 - door viewer
 - panic bar
 - panic bar with lockable lever
 - self-illuminated exit sign *
 - "green running man" self-illuminated exit sign *
 - deadbolt lock *

(* An exit sign and a deadbolt lock will not be installed together on the same door.)
- Inset white marker boards / chalk boards / natural cork tack boards.
- Eraser boxes / chalk trays
- Acoustical or non-acoustical pocket door.
- UL/ULC-listed 1 hour fire-rating (requires type MM-1, MM-1.5, or MM-2 horizontal seals).

Horizontal Seals

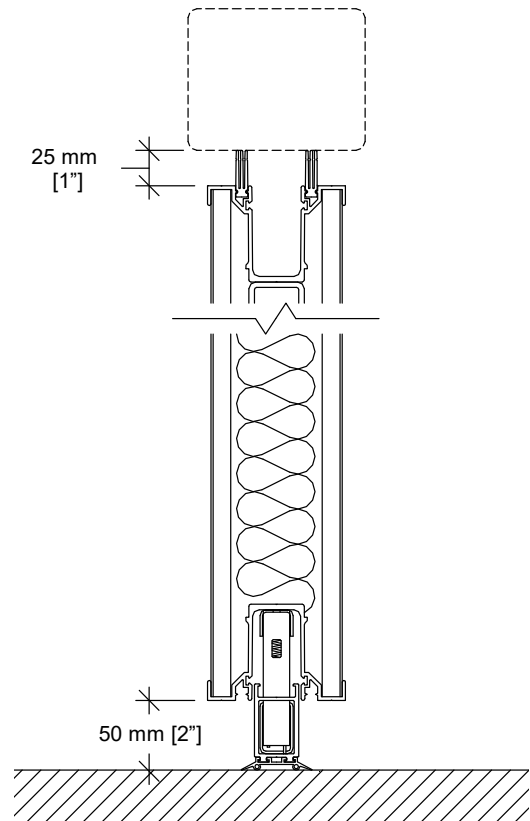

Type FA

Floor clearance : 50 mm [2"]
 Operating tolerances :
 +0 mm / -38 mm [+0" / -1 1/2"]

Horizontal Seals (cont'd)

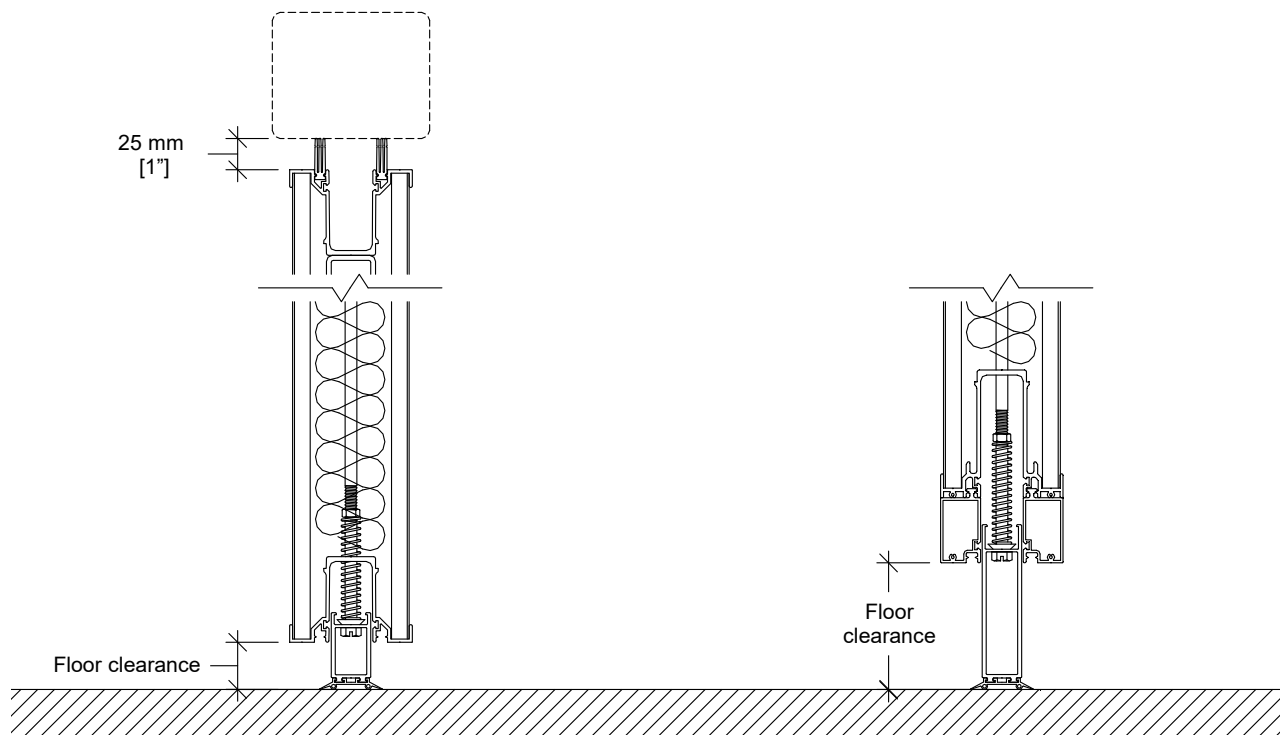

Type FM-1

Floor clearance : 25 mm [1"]
 Operating tolerances :
 +0 mm / -15 mm [+0" / -5/8"]

Type FM-1.5

Floor clearance : 38 mm [1 1/2"]
 Operating tolerances :
 +0 mm / -19 mm [+0" / -3/4"]

Type FM-2

Floor clearance : 50 mm [2"]
 Operating tolerances :
 +0 mm / -25 mm [+0" / -1"]

Type FM-2.5

Floor clearance : 64 mm [2 1/2"]
 Operating tolerances :
 +0 mm / -50 mm [+0" / -2"]

Type FM-4

Floor clearance : 102 mm [4"]
 Operating tolerances :
 +0 mm / -89 mm [+0" / -3 1/2"]

Horizontal Seals (cont'd)

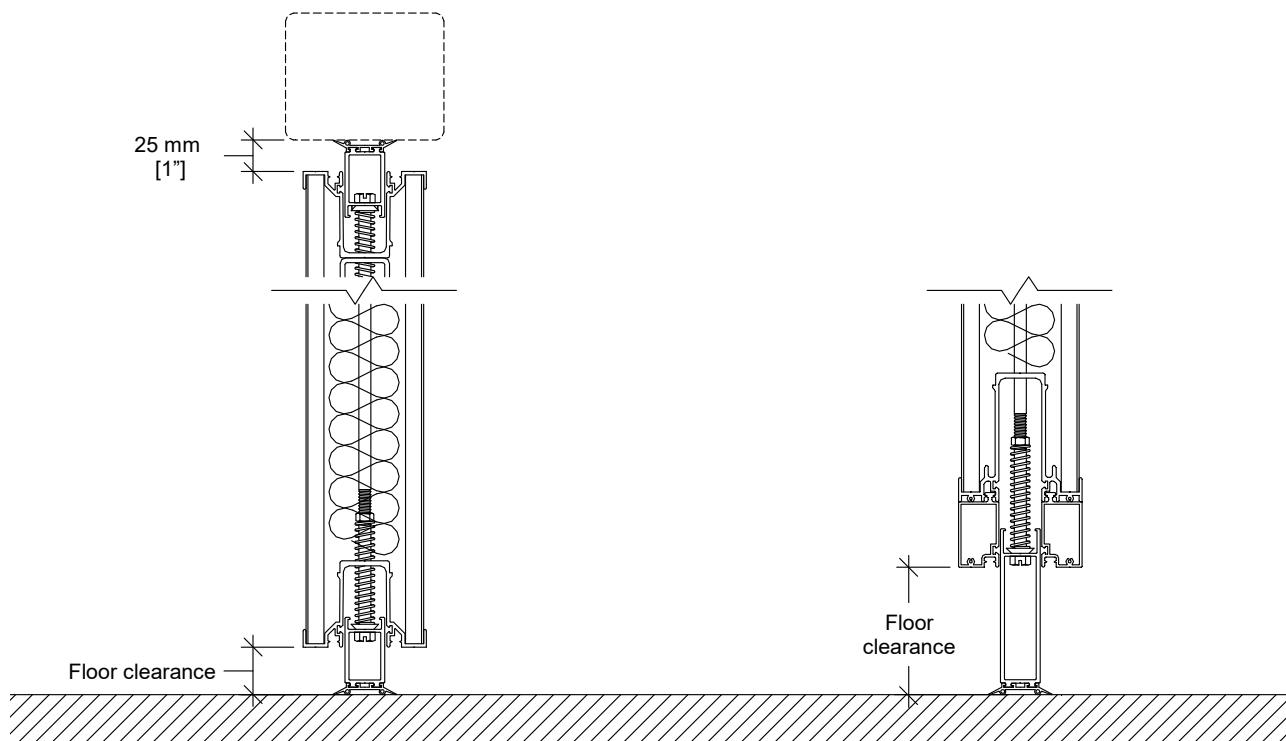

Type MM-1

Floor clearance : 25 mm [1"]
 Operating tolerances :
 +0 mm / -15 mm [+0" / -5/8"]

Type MM-1.5

Floor clearance : 38 mm [1 1/2"]
 Operating tolerances :
 +0 mm / -19 mm [+0" / -3/4"]

Type MM-2

Floor clearance : 50 mm [2"]
 Operating tolerances :
 +0 mm / -25 mm [+0" / -1"]

Type MM-2.5

Floor clearance : 64 mm [2 1/2"]
 Operating tolerances :
 +0 mm / -50 mm [+0" / -2"]

Type MM-4

Floor clearance : 102 mm [4"]
 Operating tolerances :
 +0 mm / -89 mm [+0" / -3 1/2"]

Horizontal Seals (cont'd)

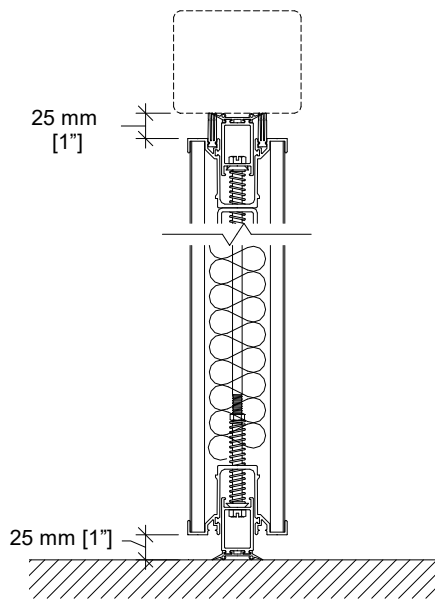

Type MM-55 (STC 55 only)
 Floor clearance : 25 mm [1"]
 Operating tolerances :
 +0 mm / -15 mm [+0" / -5/8"]

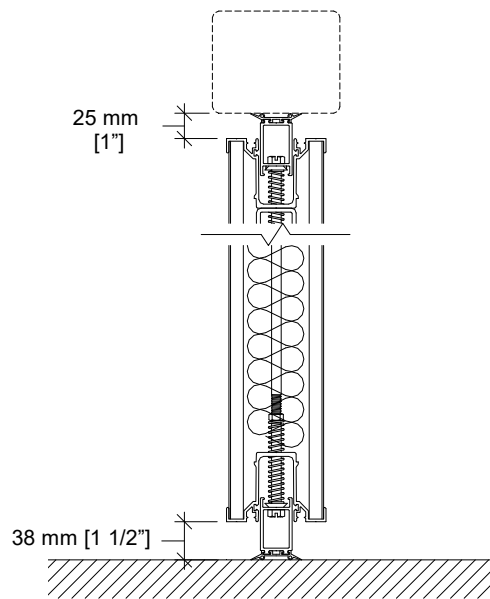

Type AA
 Floor clearance : 38 mm [1 1/2"]
 Operating tolerances :
 +0 mm / -19 mm [+0" / -3/4"]

Elevation

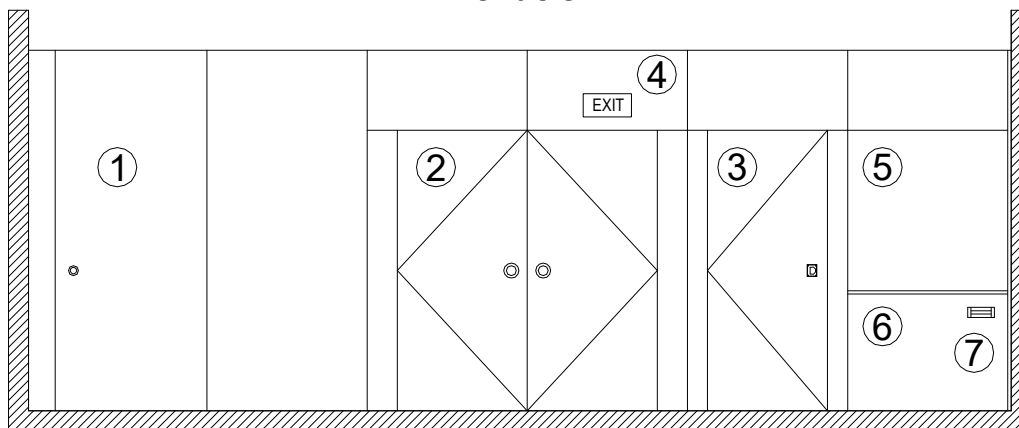

- | | |
|-------------------------------|-----------------|
| 1- Telescopic closure panel | 5- Work surface |
| 2- Double pass doors | 6- Chalk tray |
| 3- Single pass door | 7- Eraser box |
| 4- Self-illuminated exit sign | |



MODERCO

Vertical Section

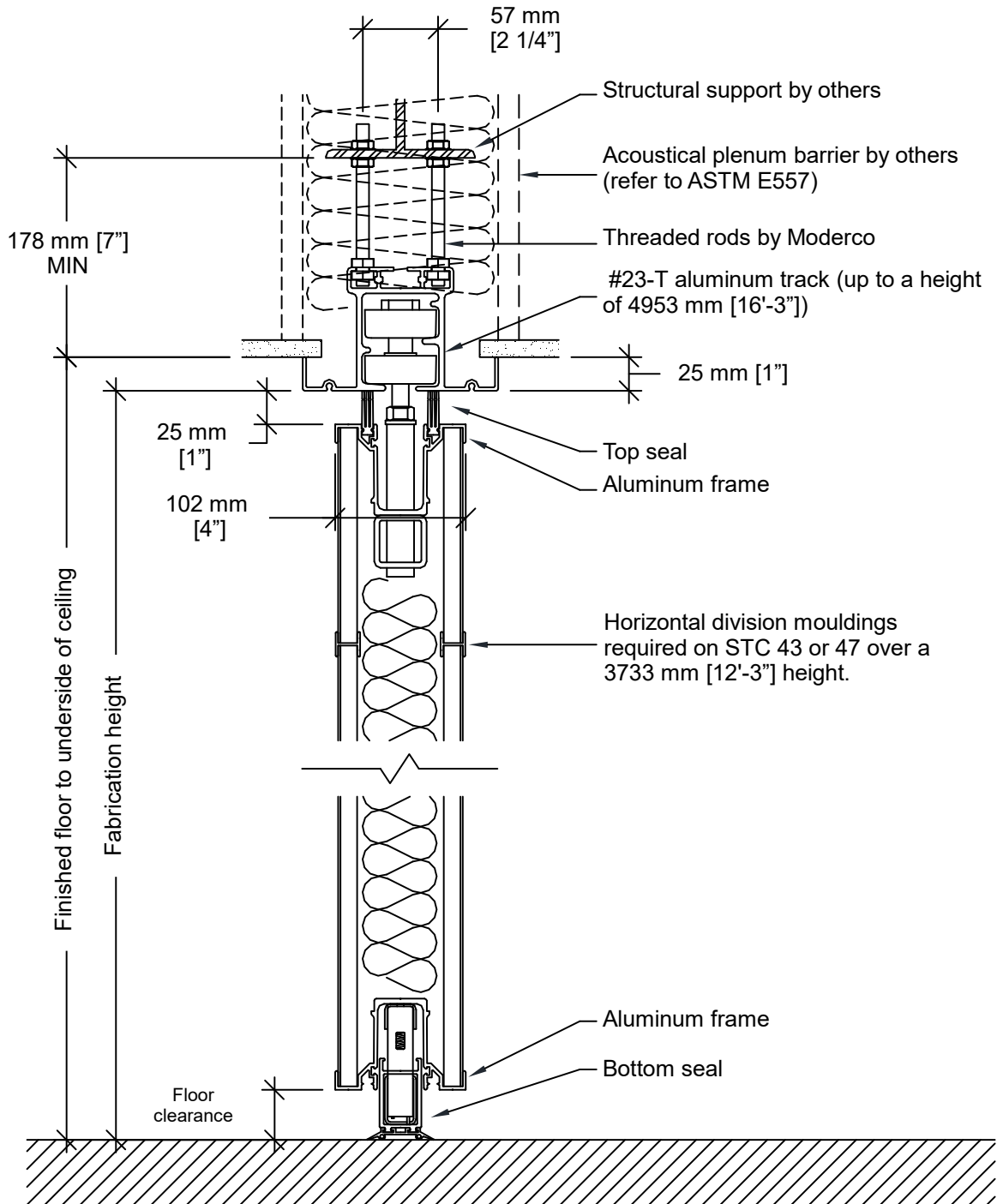

Track Options

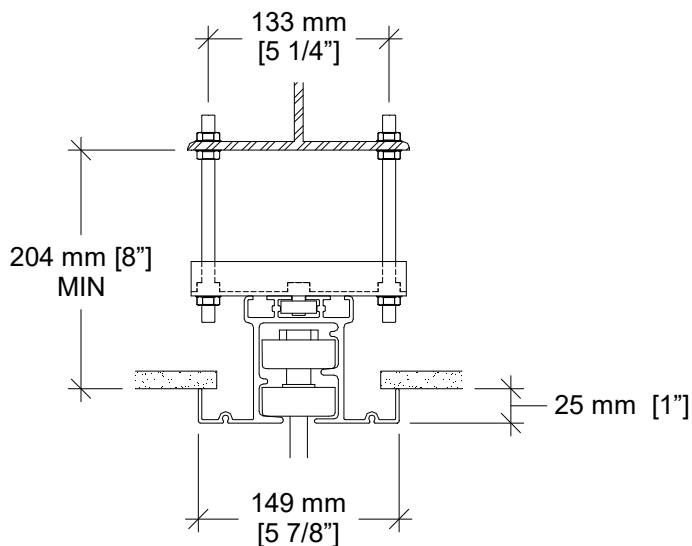

#23-T track with optional hanger bracket

Hanger bracket required for installations where the topmost nuts cannot be used for adjustment.

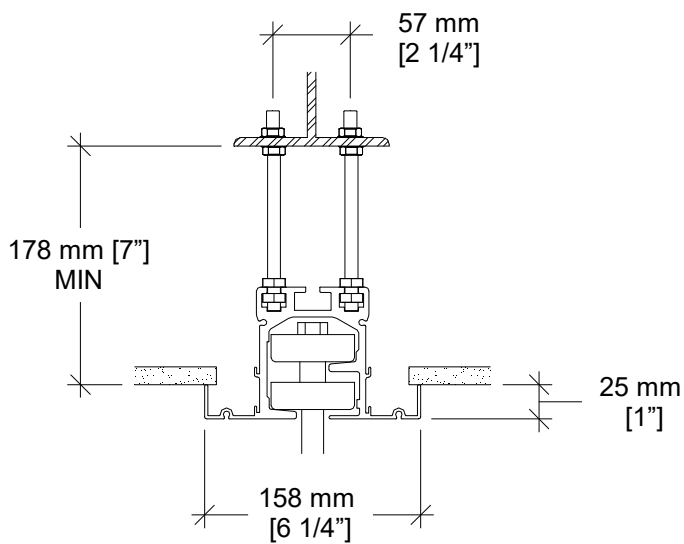

#33-T aluminum track

Standard for partitions from a height of 4953 mm [16'-3"] up to 6781 mm [22'-3"].

Optional for partitions up to 4343 mm [14'-3"].

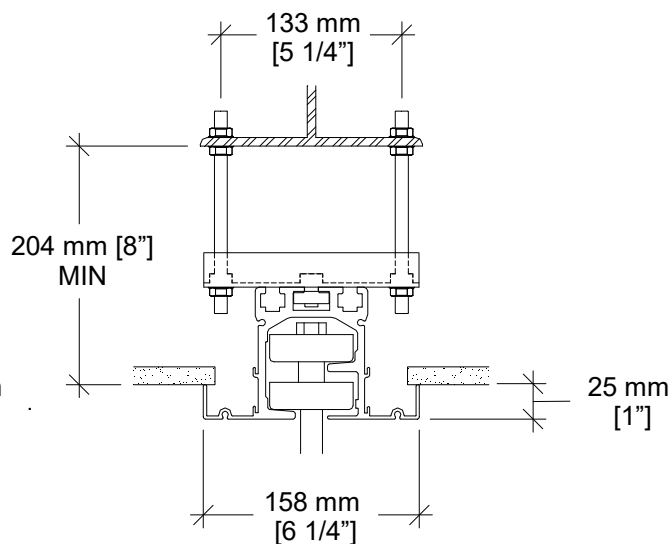

#33-T aluminum track with optional hanger bracket

Track Options (cont'd)

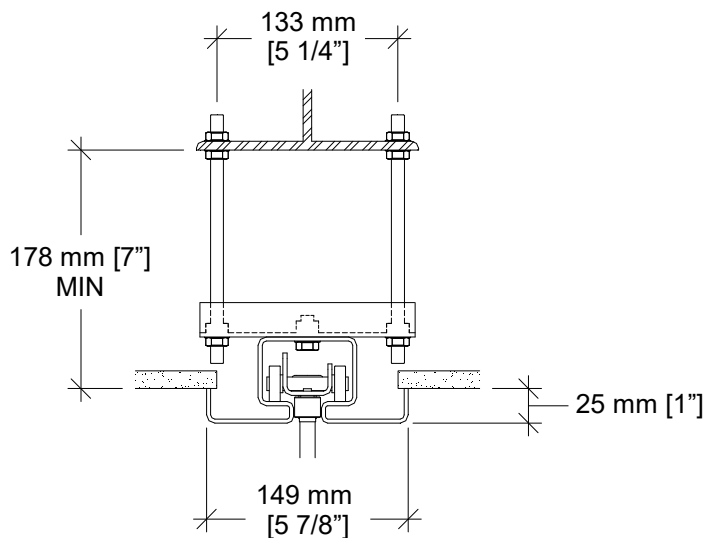

#72 steel track with hanger bracket

Optional for partitions up to 4953 mm [16'-3"].

Programmable switches.

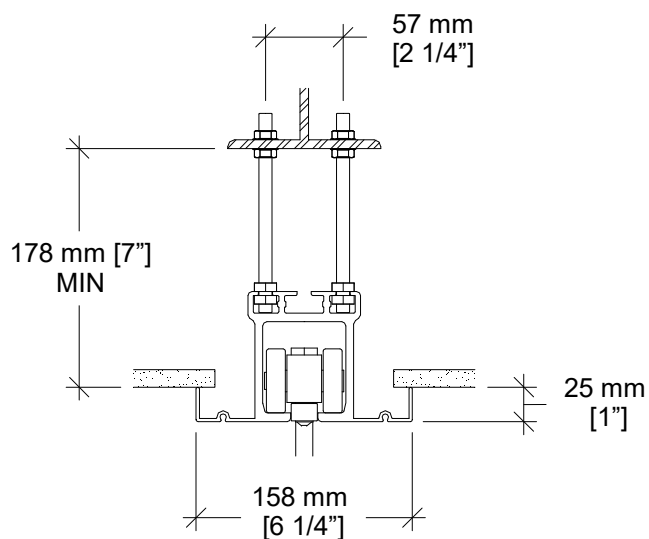

#55-T aluminum track

Standard for partitions from a height of 6781 mm [22'-3"] up to 9220 mm [30'-3"].

Optional for partitions up to 6781 mm [22'-3"].

Programmable switches.

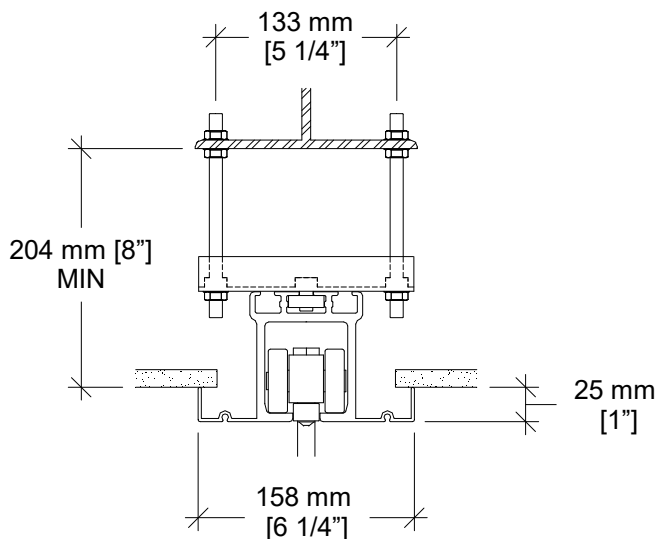

#55-T aluminum track with optional hanger bracket

Plan Views

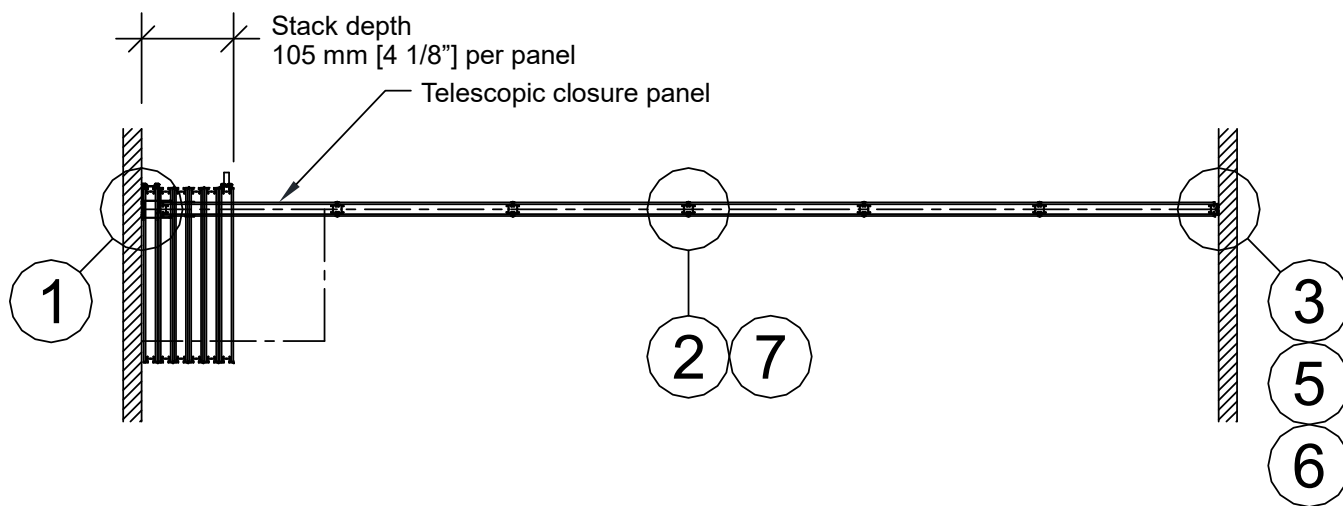

Telescopic closure panel

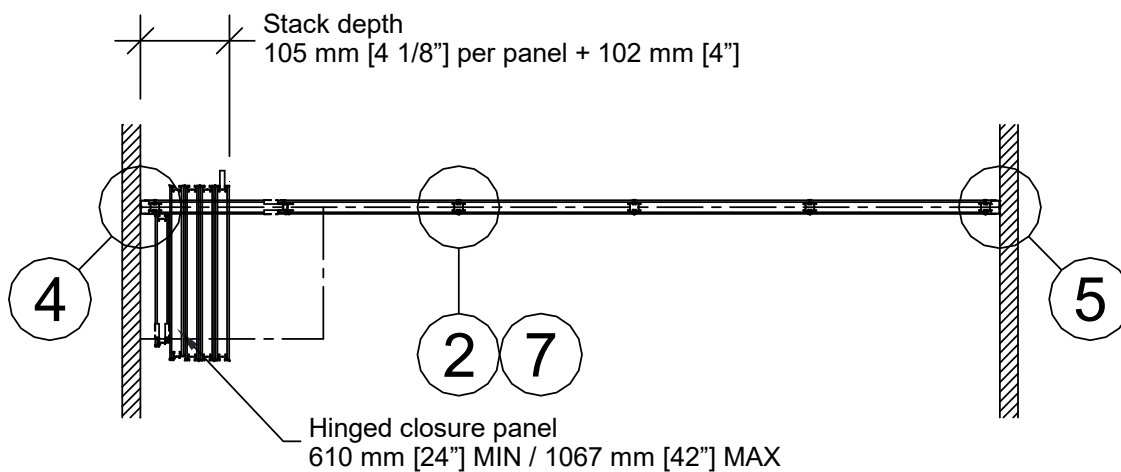

Hinged closure panel

Horizontal Sections

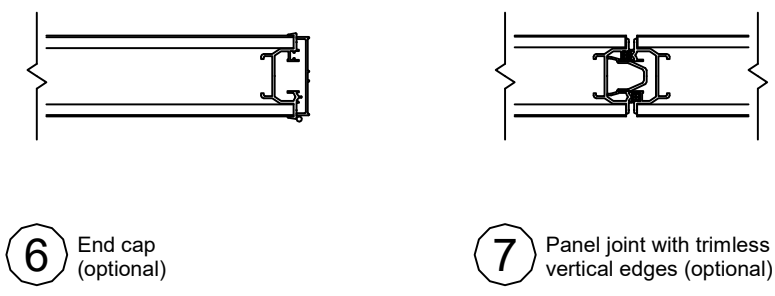
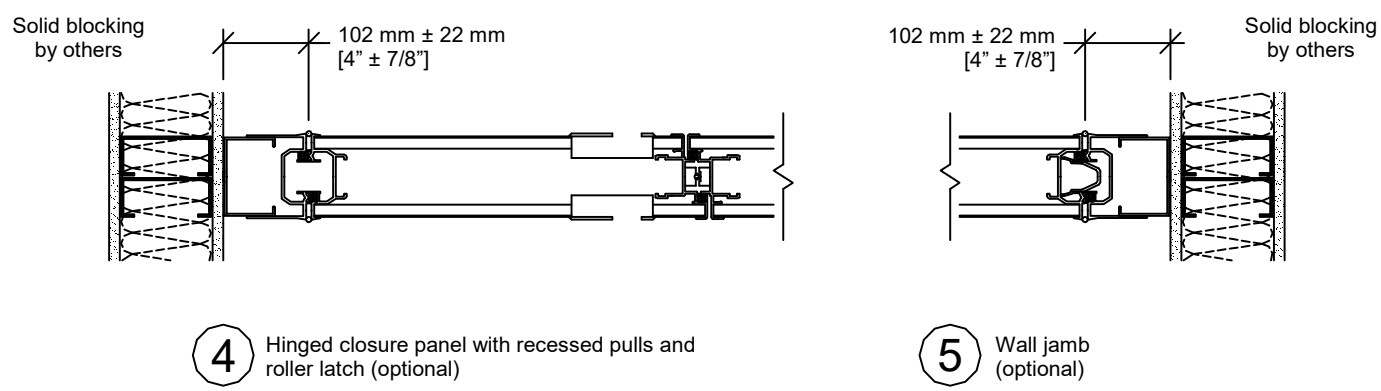
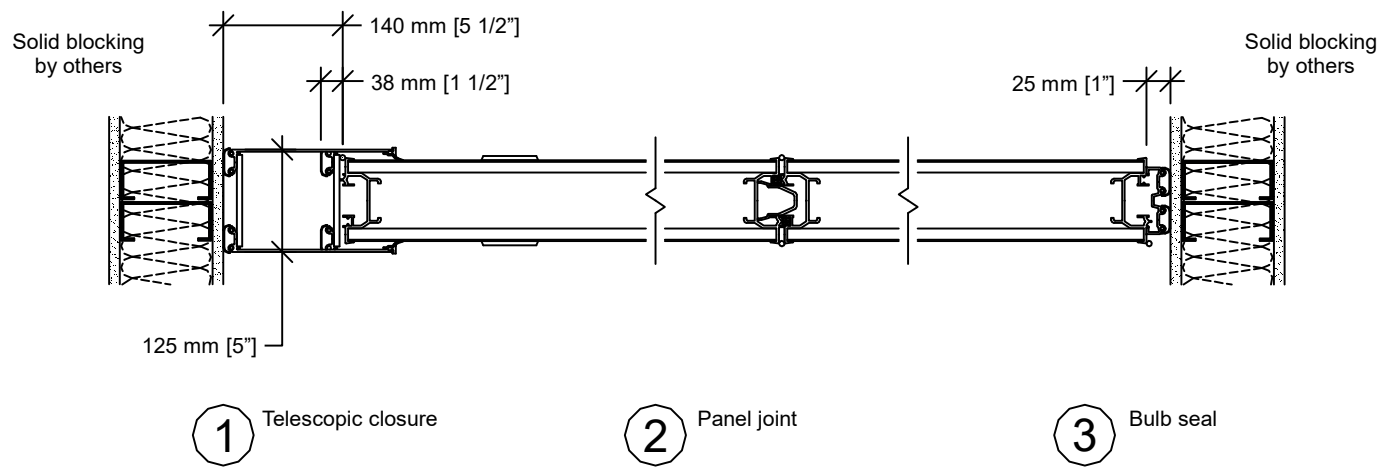

Typical Layouts - #23-T & #33-T Tracks

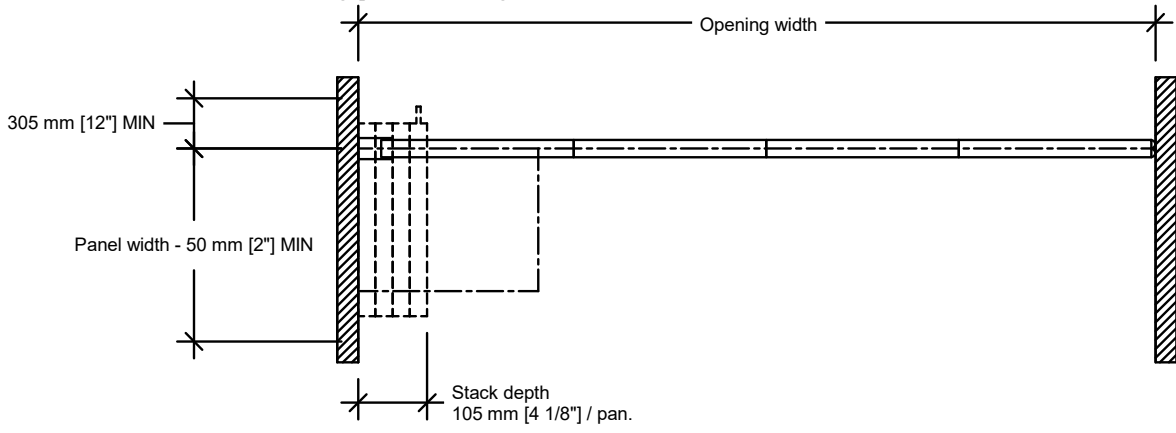

Wall to wall Side Stack – telescopic closure

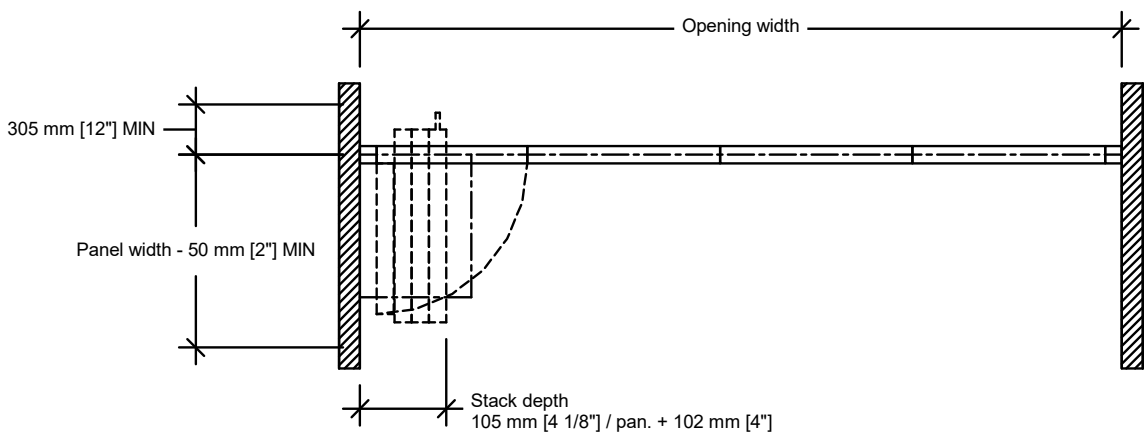

Wall to wall Side Stack – hinged closure

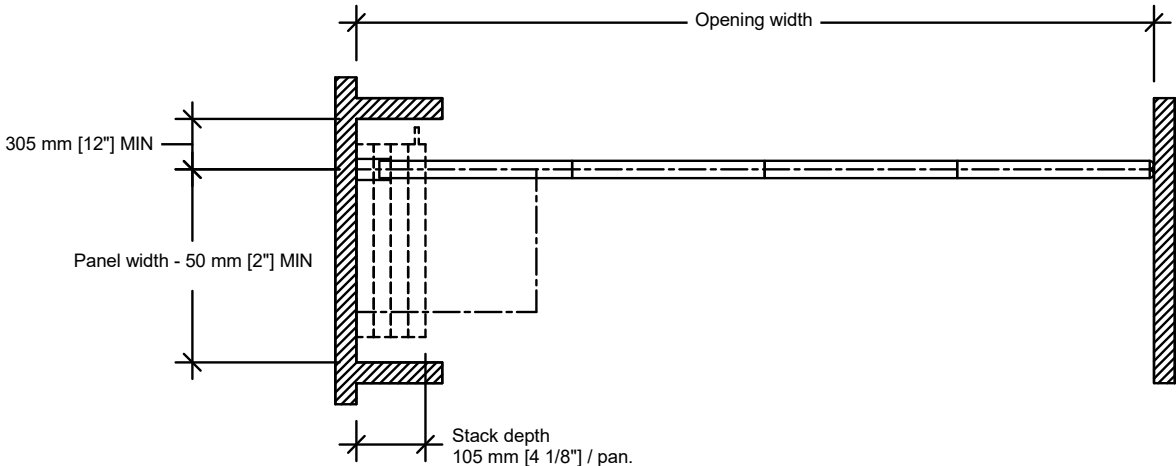

Pocket

Typical Layouts - #23-T & #33-T Tracks (cont'd)

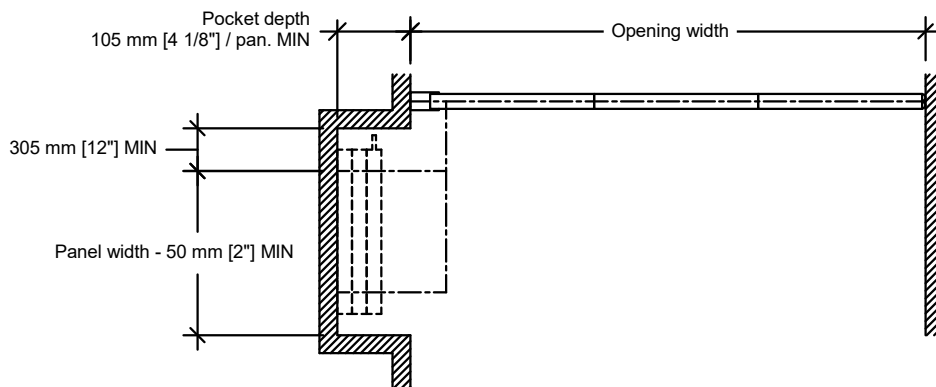

Remote Stack

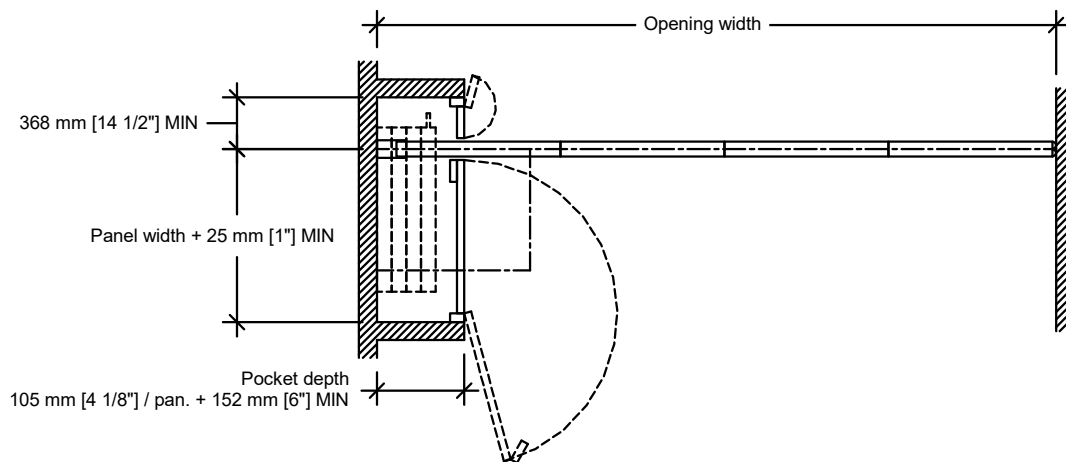

**Pocket and PN-3 non-acoustical pocket door
(partition seals to back of pocket)**

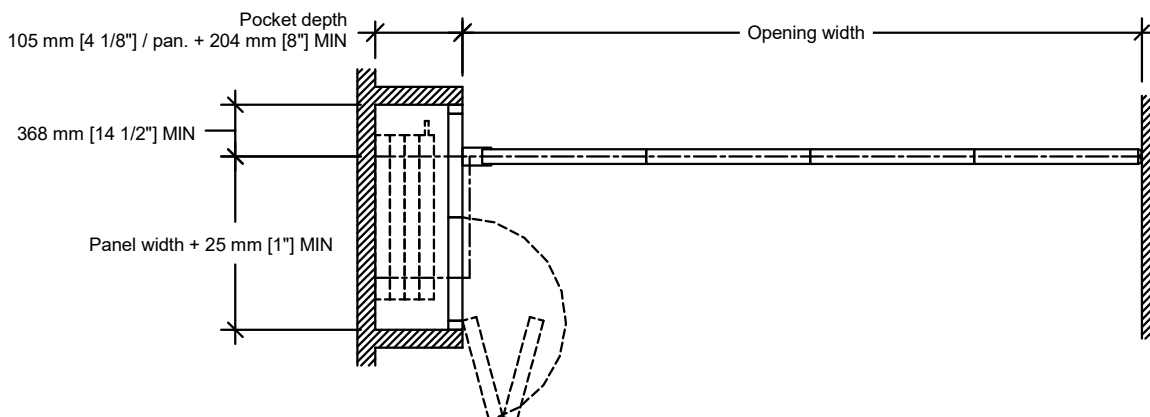

**Pocket and PA-2B acoustical pocket door
(partition seals to face of pocket door)**



MODERCO

Typical Layouts - #72 & #55-T Tracks

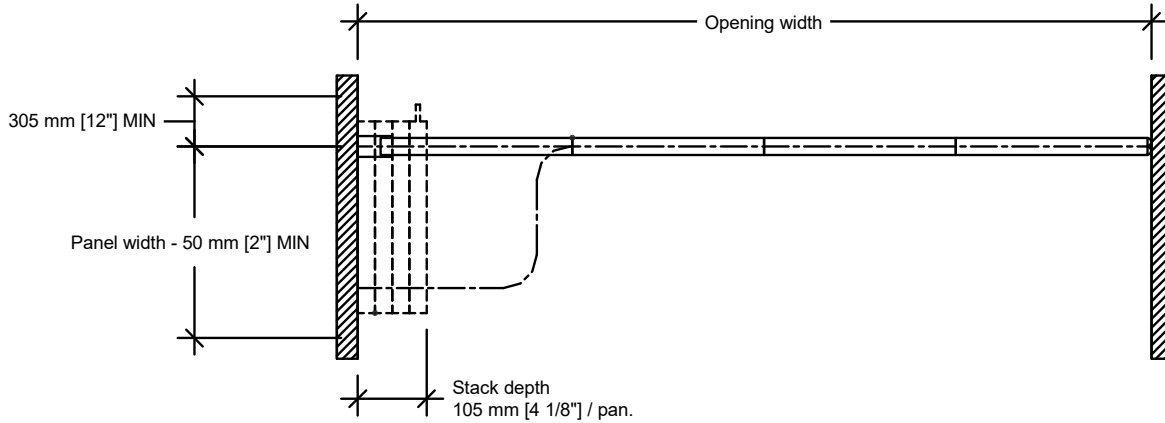

Side Stack – bi-folding telescopic closure

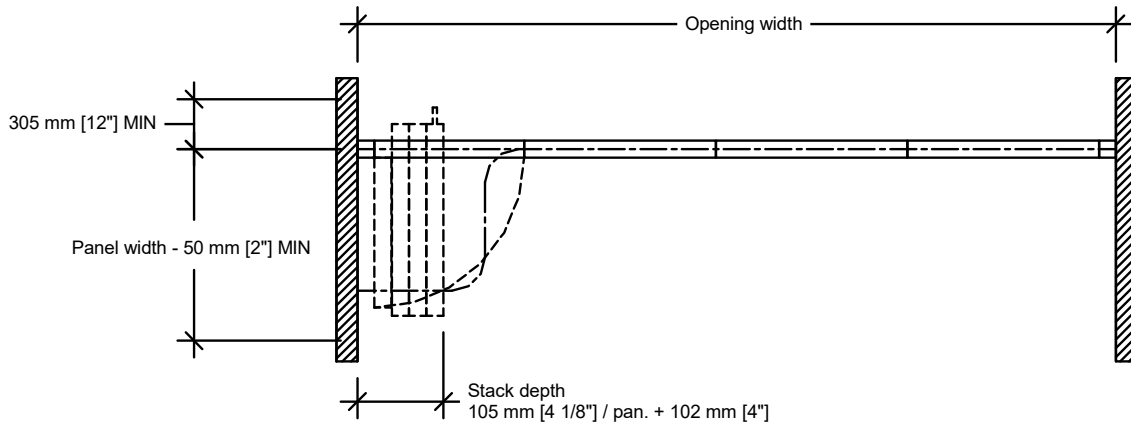

Side Stack – hinged closure (7 panels max)

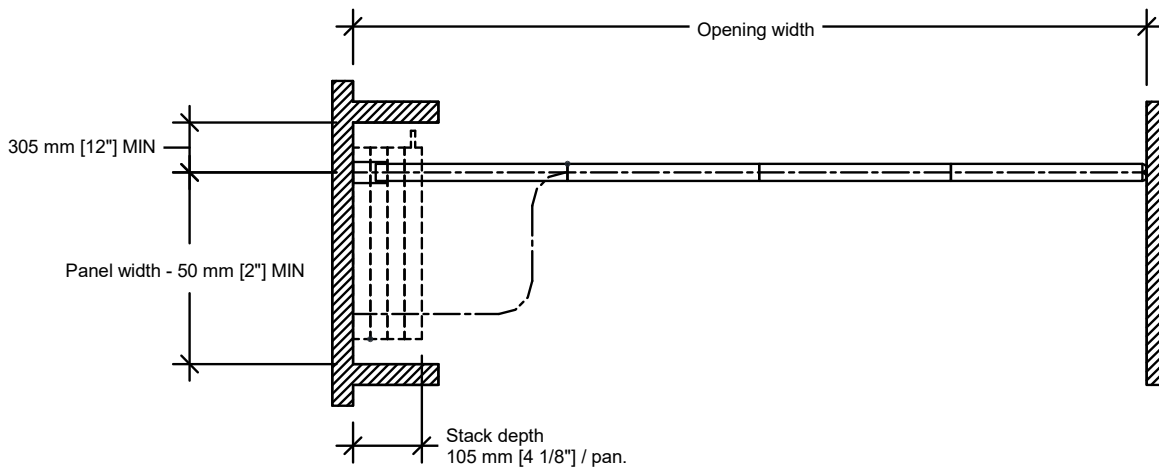

Pocket

Typical Layouts - #72 & #55-T Tracks (cont'd)

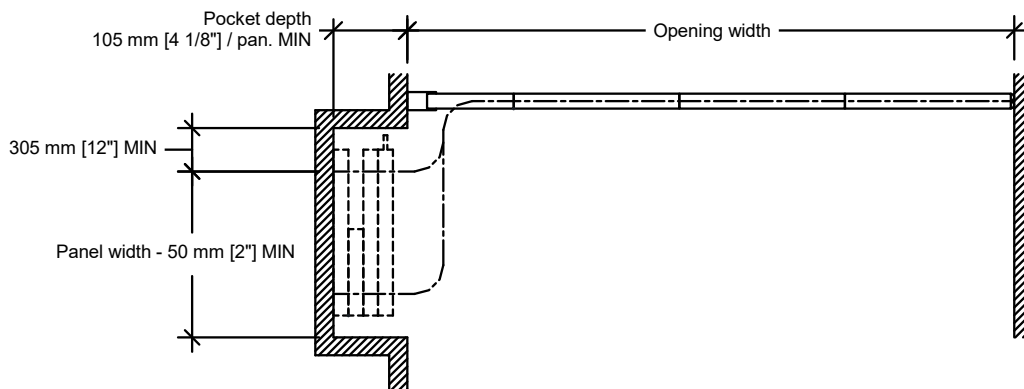

Remote Stack

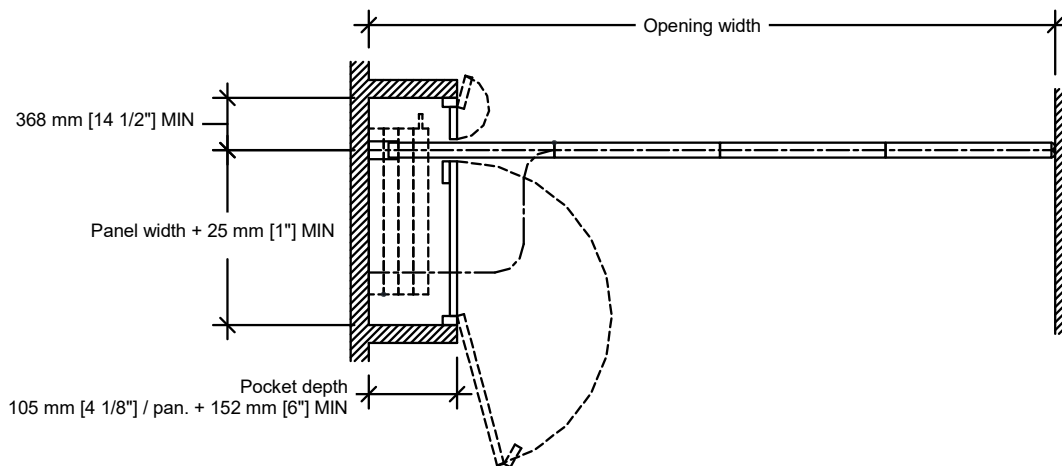

**Pocket and PN-3 non-acoustical pocket door
(partition seals to back of pocket)**

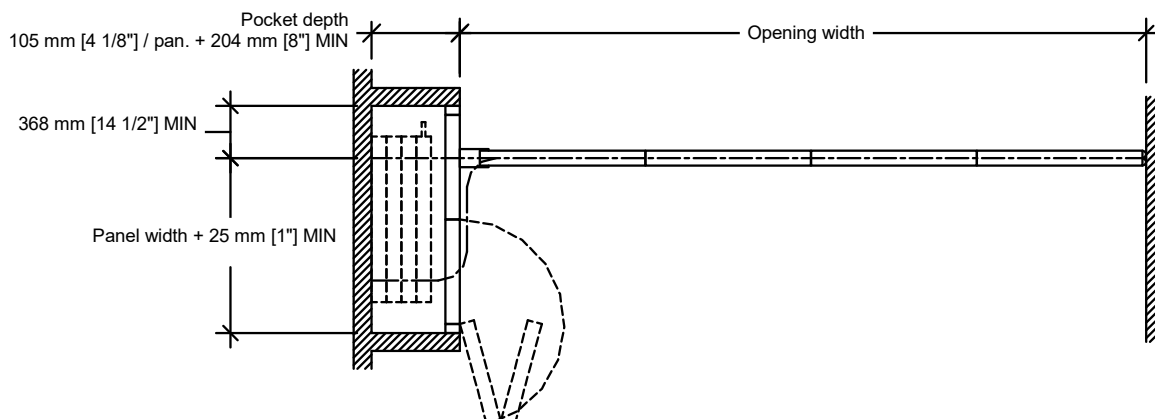

**Pocket and PA-2B acoustical pocket door
(partition seals to face of pocket door)**