

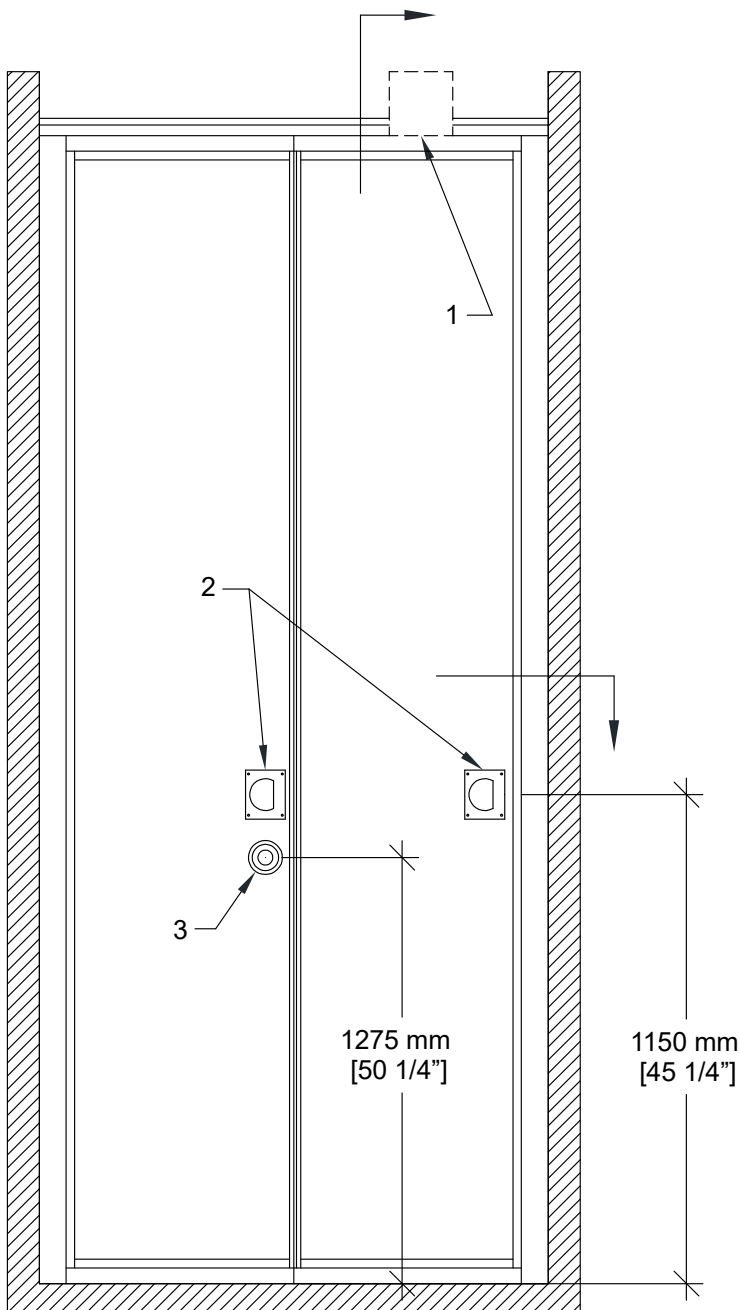

MODERCO

Série Signature 800

Technical Data Sheet Signature 800 PN-82B Pocket Door



PN-82B Non-acoustical Pocket Door

- 2 bi-folding sections
- Same basic construction as movable partition panels
- Same surface finish as movable partition / optional custom finish / unfinished
- Same frame finish as movable partition / optional custom finish
- Top and bottom locking bolts
- Low profile hinges
- Optional deadbolt lock

- 1- Track
- 2- Flush pulls
- 3- Top and bottom locking bolt activator

Vertical Section

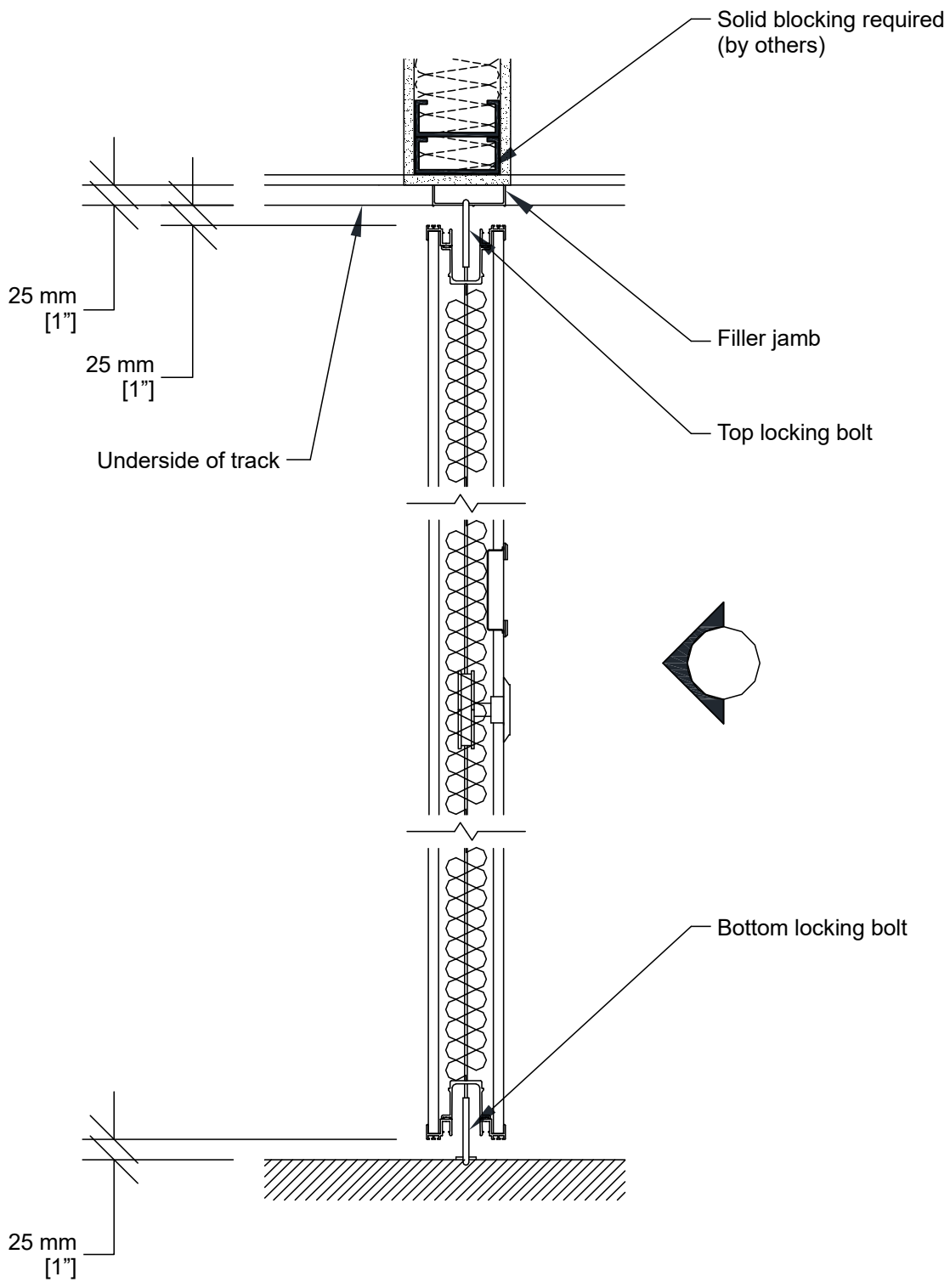

Horizontal Section

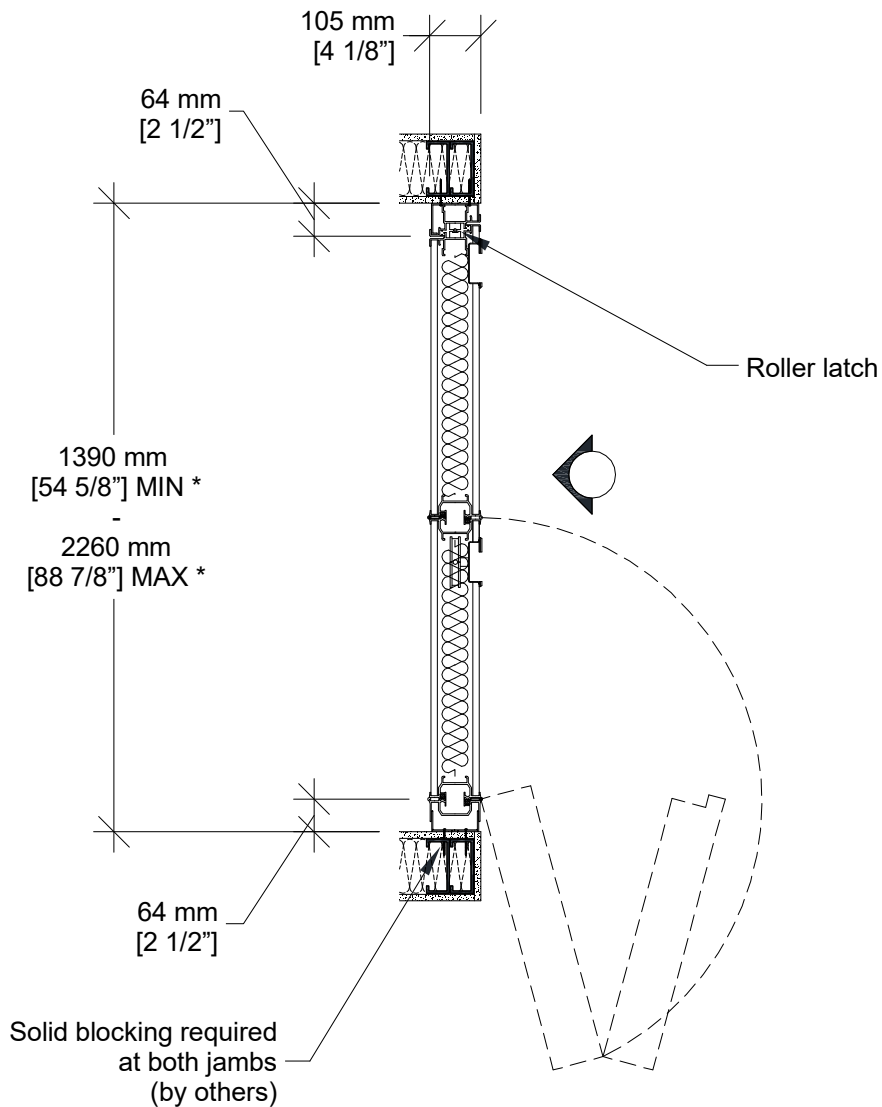

* Min/Max dimensions are fabrication limits and do not account for job-specific conditions.

Please consult shop drawings or local Moderco distributor prior to sizing pockets.