

## Technical Data Sheet Signature 843-E

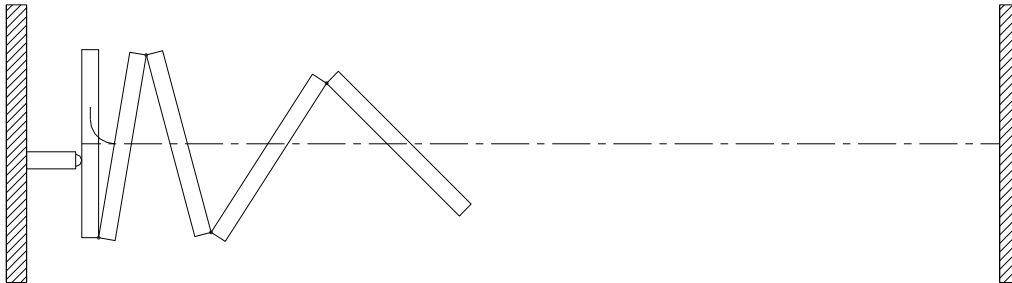

### **Features & Options**

#### **Standard Features**

- Electrically-operated continuously-hinged movable partition.
- Driven with Ø5 mm [3/16"] steel cable.
- STC 43 or 47 with gypsum board faces.
- STC 49 or 52 with steel faces laminated to gypsum board.
- 102 mm [4"] nominal thickness. 1230 mm [48 1/2"] maximum width.
- Clear-anodized steel-reinforced aluminum frame.
- Protective trims on entire perimeter.
- Combination aluminum and vinyl tongue and groove vertical sound seals between panels.
- Final closure by lateral wall jamb.
- Type FF horizontal seals :
  - Fixed top and bottom sweeps
  - bottom seals provide a 50 mm [2"] floor clearance
- Low profile steel hinges.
- Clear-anodized 6063-T6 alloy aluminum track.

- Each panel supported by one 4-wheeled carrier with steel tires over hardened steel ball bearing wheels.
- Vinyl wallcovering.
- Maximum height: 6780 mm [22'-3"]  
Maximum length: 19810 mm [65'-0"]
- UL/ULC listed drive unit with NEMA-1 motor enclosure and controls and control enclosure conform to ANSI/NEMA ICS1, ICS 2 and ICS 6.
- 1.5 hp / 120 V / 1 ph / 60 Hz
- Travel controlled by limit switches.
- Operation by two simultaneously-activated key switches located on each side of the partition.

#### **Optional Features and Accessories**

- STC 49 or 52 with gypsum board faces and steel backing.
- Powder-coated protective trims and/or track.
- Upgraded wallcoverings: fabric, vertically-ribbed carpet, plastic laminate, full-height marker board, wood veneer, custom finishes.
- Owner-supplied wallcovering (approval required).

**Optional Features and Accessories (cont'd)**

- ADA-compliant pass door with flush pulls and roller latch.
- Door options:
  - concealed automatic closer
  - window frame
  - door viewer
  - self-illuminated exit sign \*
  - "green running man" self-illuminated exit sign \*
  - deadbolt lock \*
 (\* An exit sign and a deadbolt lock will not be installed together on the same door.)
- Inset white marker boards.
- Inset chalk boards.
- Inset natural cork tack boards.
- Eraser boxes.
- 3-section pocket door fitted with limit switches to prevent operation of the partition until the pocket door is fully opened.

**Horizontal Seals**

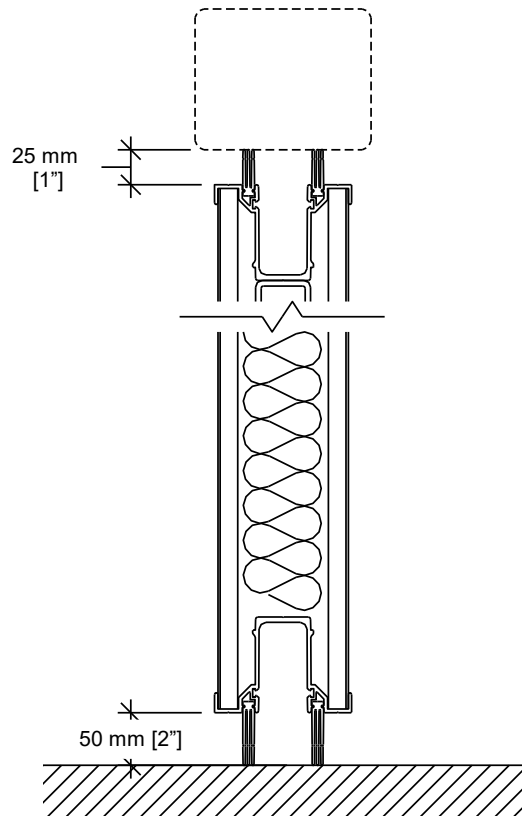

**Type FF**

Floor clearance : 50 mm [2"]

Operating tolerances :

+0 mm / -38 mm [+0" / -1 1/2"]

### Vertical Section

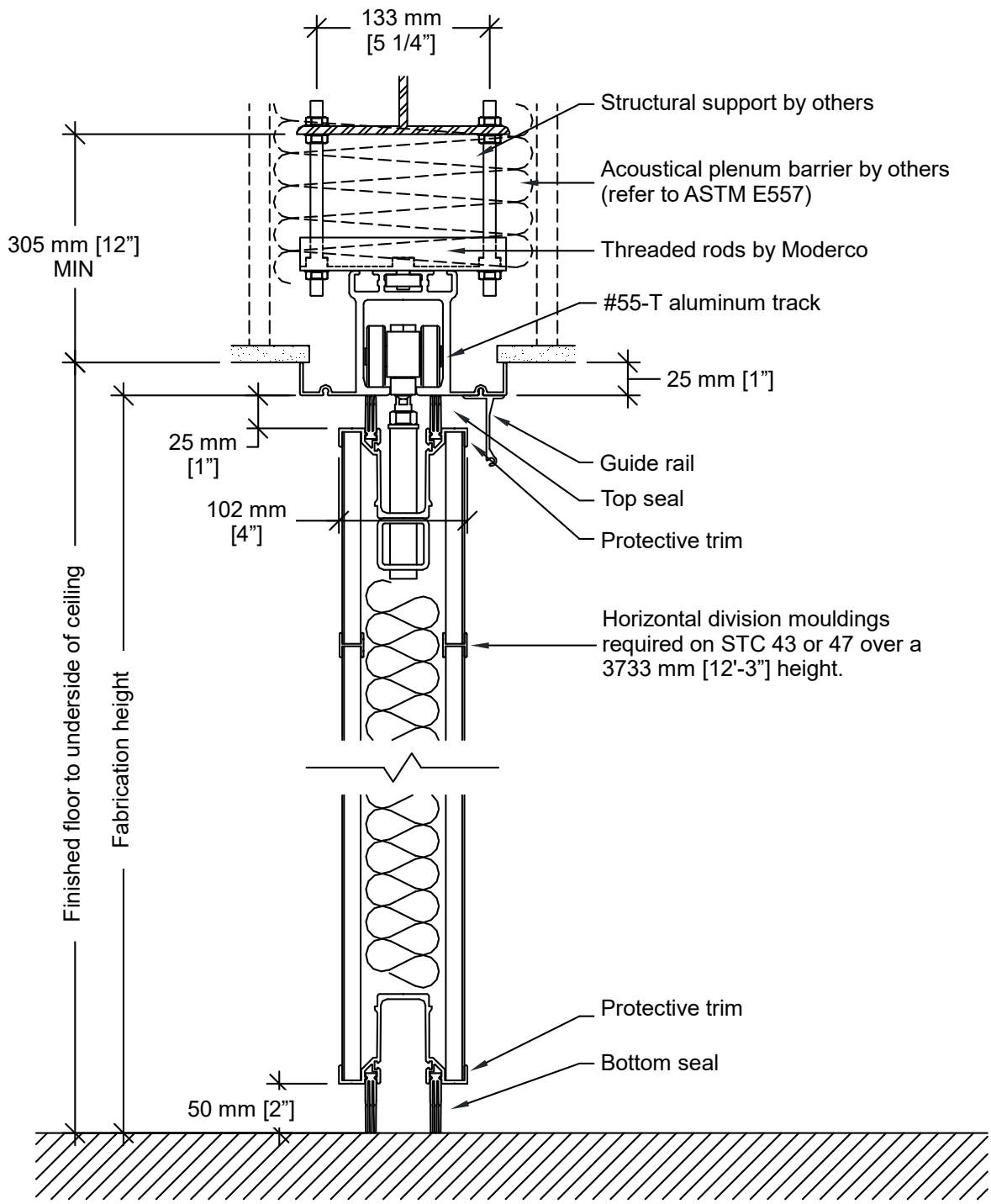

**Plan Views**

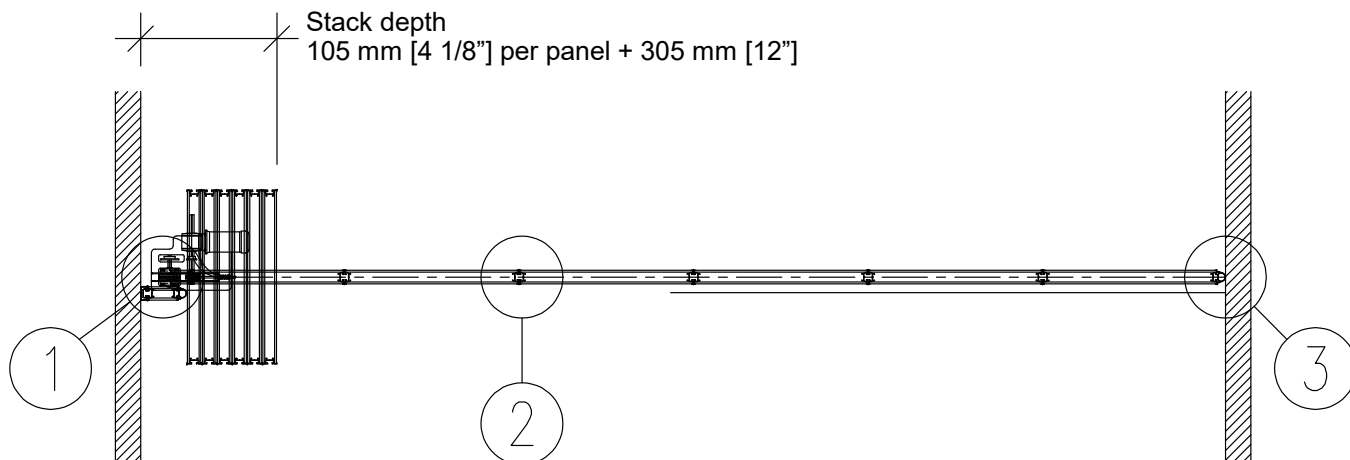

**Wall to wall**

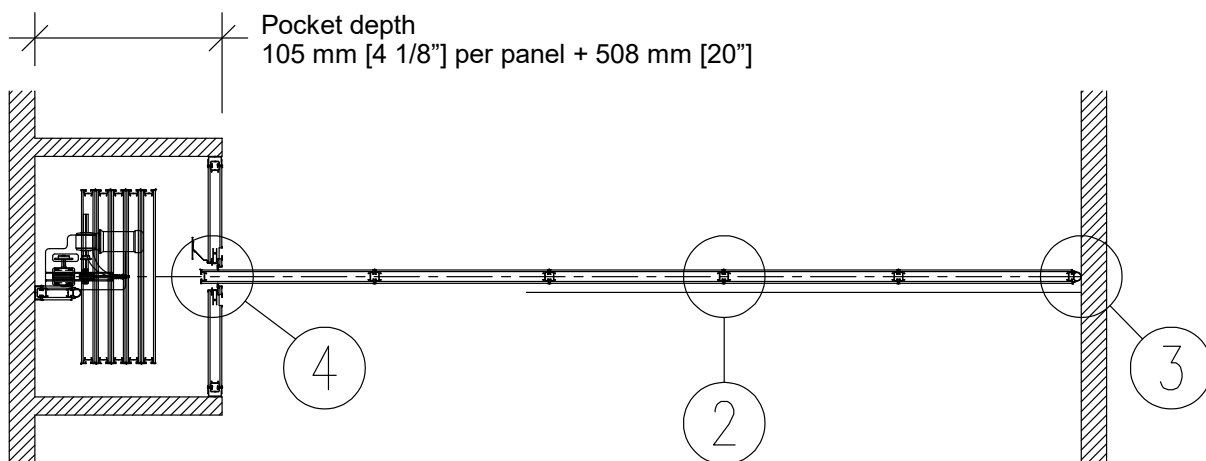

**Wall to pocket with PA-83 acoustical pocket door**

### Horizontal Section

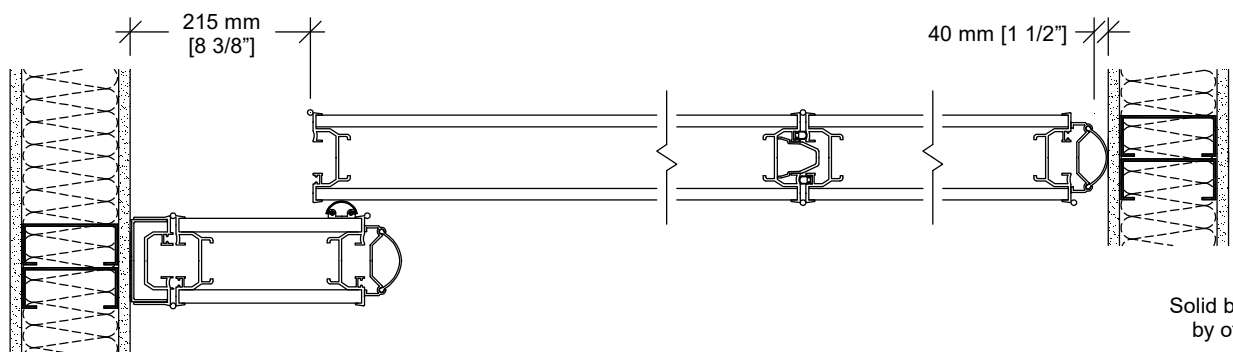

Solid blocking by others



Side jamb closure



Panel joint



Bulb seal

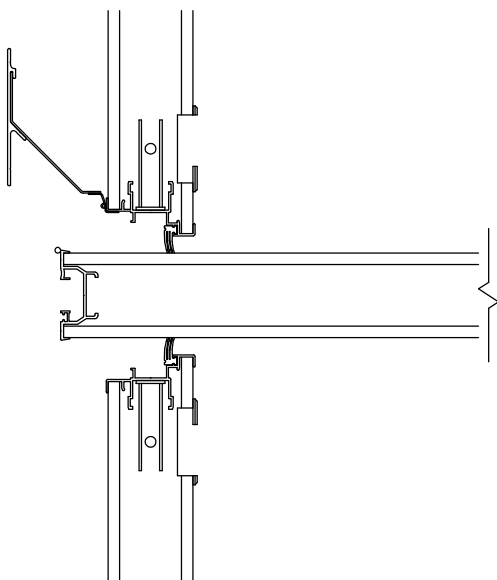

Closure at pocket door (optional)

### Elevation

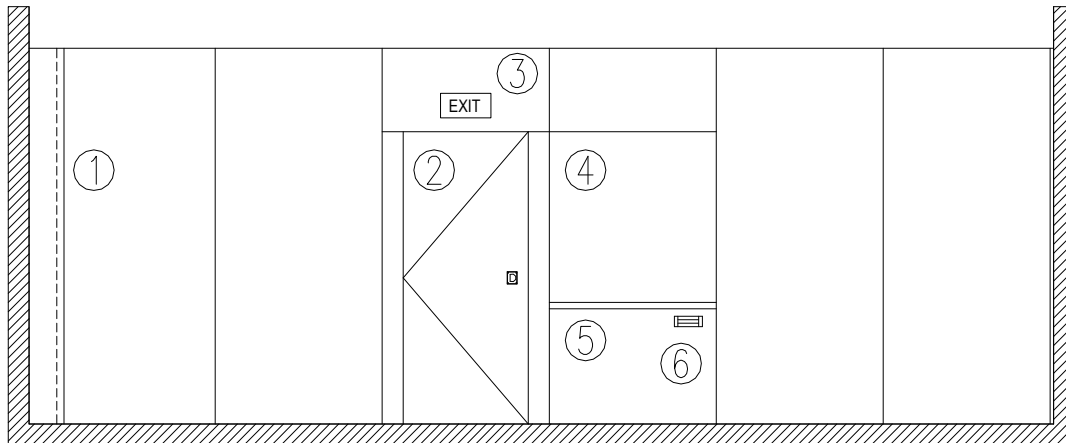

- |                               |                 |
|-------------------------------|-----------------|
| 1- Closure panel              | 4- Work surface |
| 2- Single pass door           | 5- Chalk tray   |
| 3- Self-illuminated exit sign | 6- Eraser box   |

**Drive Unit**

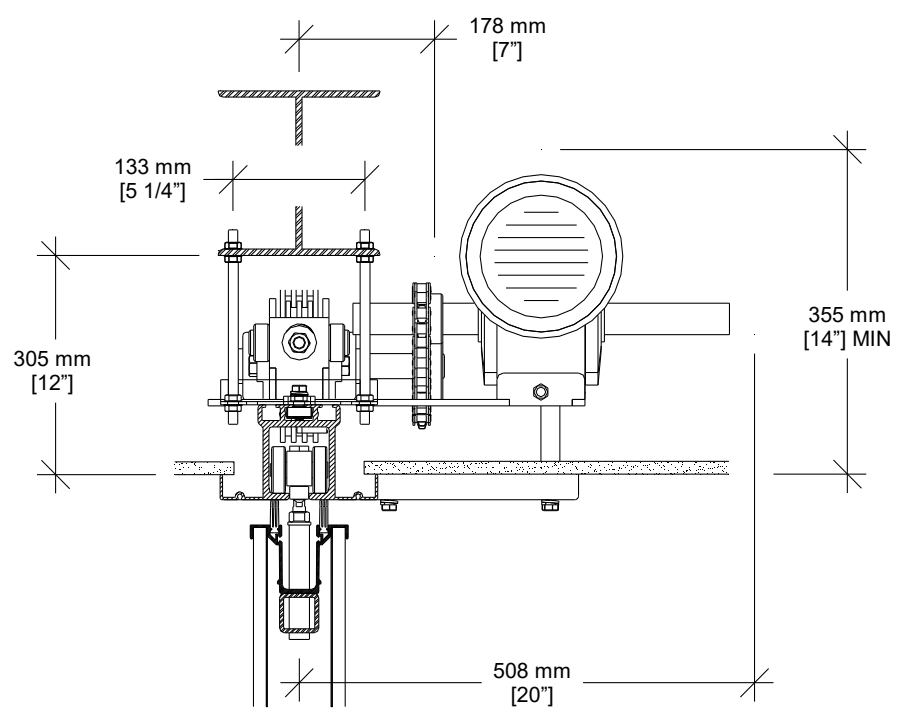

**Optional Safety Devices**

