

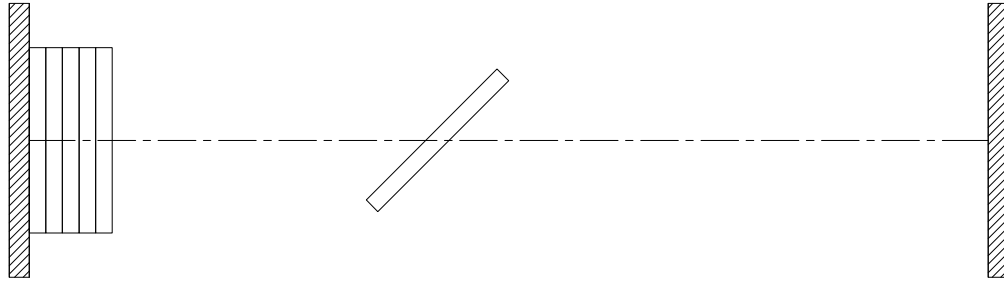

MODERCO

Crystal 200 Series

Technical Data Sheet Crystal 240



Features & Options

Standard Features

- Manually-operated single-point individual-panel glass movable partition.
- STC 44.
- 102 mm [4"] nominal thickness. 1230 mm [48 1/2"] maximum width.
- Clear-anodized steel-reinforced aluminum frame.
- Protective trims on the entire perimeter.
- Combination aluminum and vinyl tongue and groove vertical sound seals between panels.
- Final closure by telescopic jamb.
- Type MM-1.5 horizontal seals:
 - top and bottom retractable seals
 - Manually-operated, simultaneously-activated top and bottom seals
 - bottom seals provide a 38 mm [1 1/2"] floor clearance
- Clear-anodized 6063-T6 alloy aluminum track.
- Each panel supported by one carriers made up of four vertically-aligned precision-ground hardened steel ball bearing wheels with nylon tires.

- 6 mm [1/4"] clear tempered glass faces.

- Maximum height : 3733 mm [12'-3"].

Optional Features and Accessories

- Powder-coated frame and/or track.
- 11 ga. steel track, painted white.
- Glass finishes : stained, colored, acid washed, frosted, etc.
- Battery-powered electrically tilting blinds and operated by remote control.
- Final closure by pivot panel.
- Inset white marker boards / chalk boards / natural cork tack boards.
- Chalk tray.
- Acoustical or non-acoustical pocket door.

Horizontal Seals

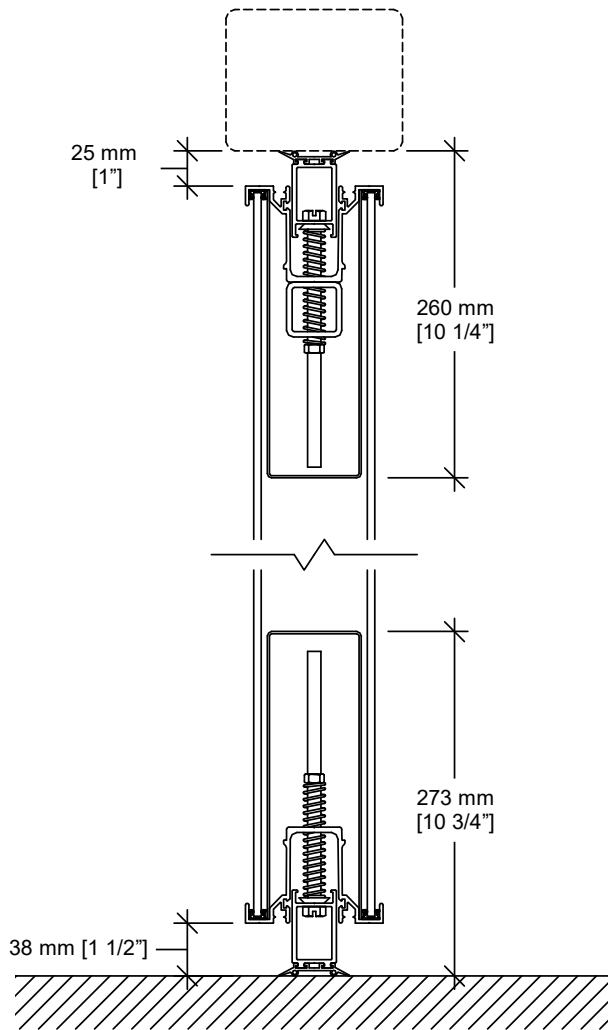

Type MM-1.5

Floor clearance : 38 mm [1 1/2"]

Operating tolerances :

+0 mm / -19 mm [+0" / -3/4"]

Vertical Section

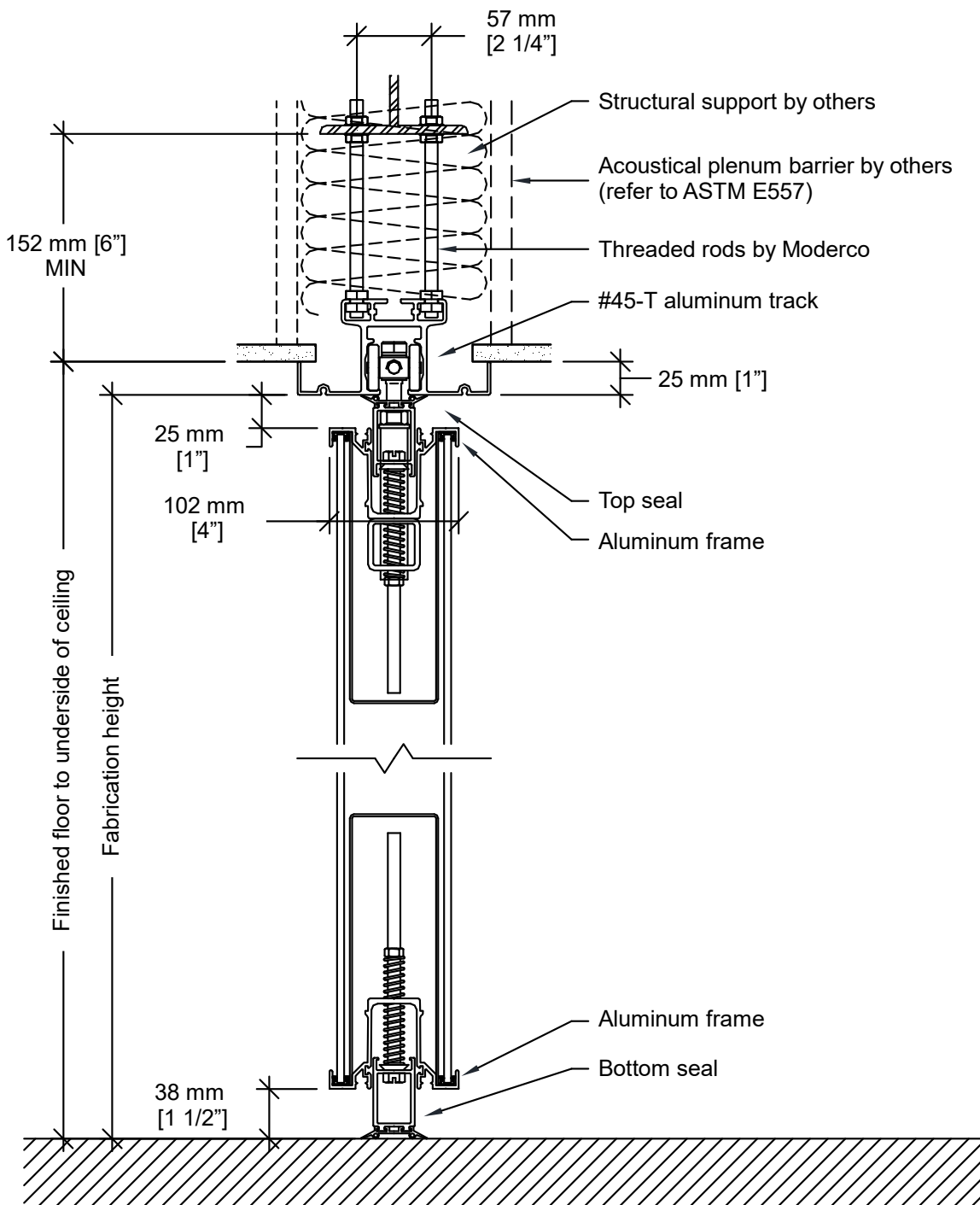



MODERCO

Track Options

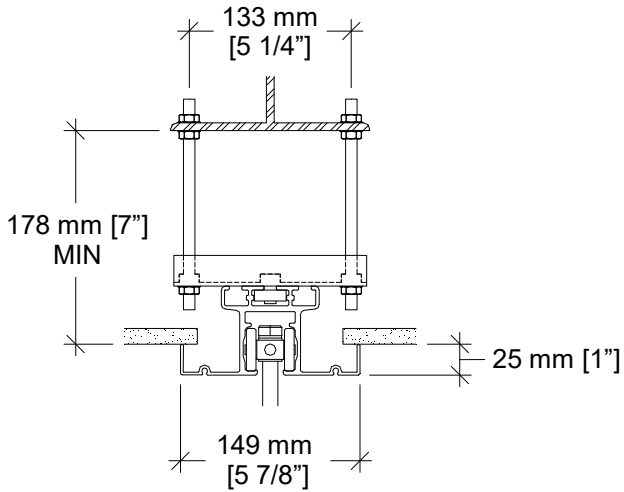

Optional hanger bracket

Required for installations where the topmost nuts cannot be used for adjustment.

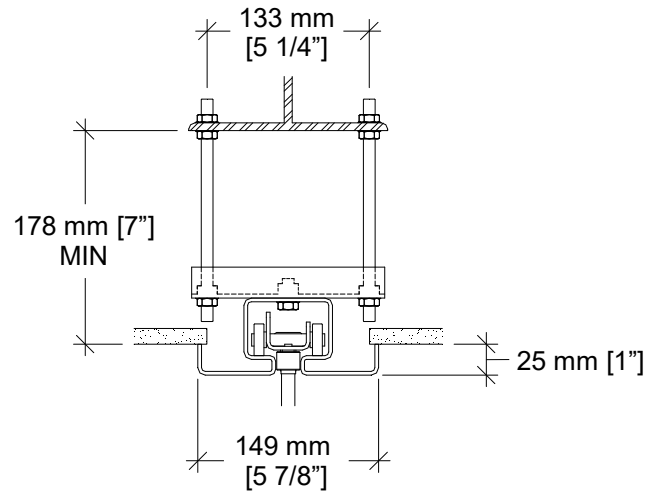

**#72 steel track
with hanger bracket**

Elevation

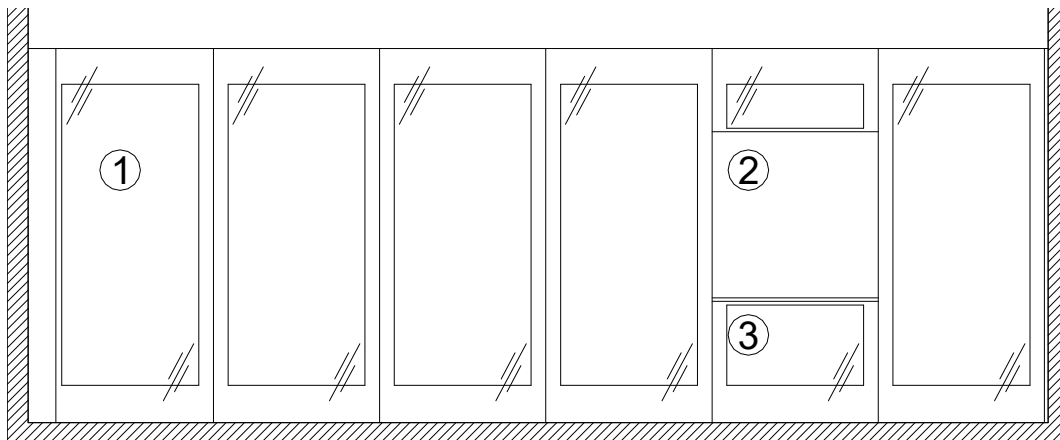

- 1- Telescopic closure panel
- 2- Work surfaces
- 3- Chalk tray



MODERCO

Plan Views

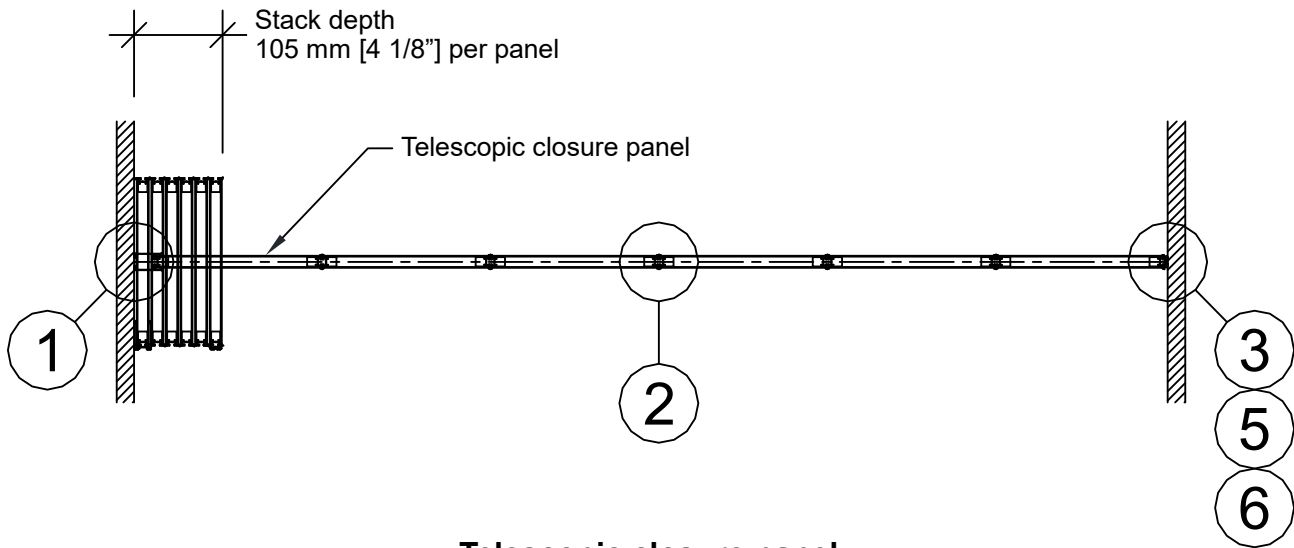

Telescopic closure panel

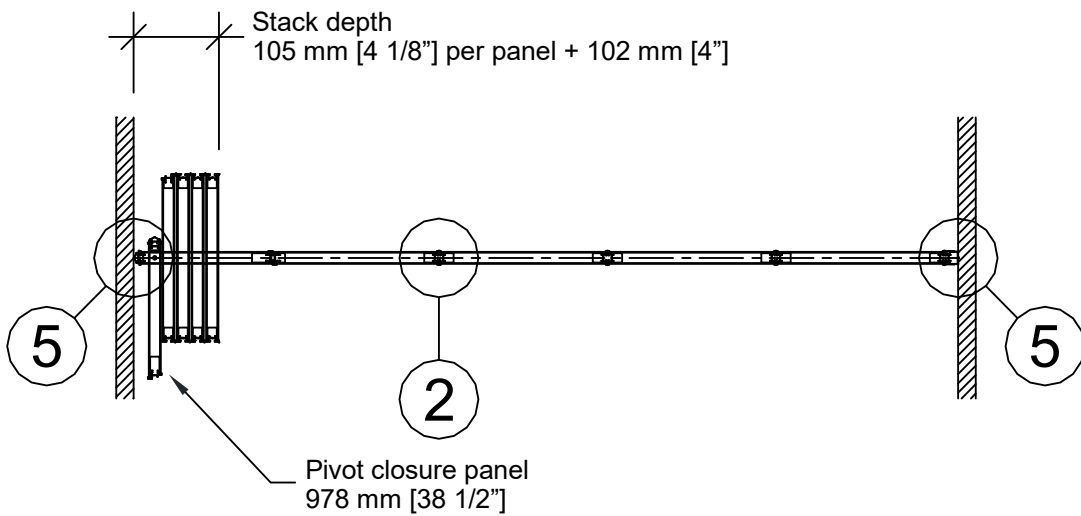

Pivot closure panel

Horizontal Sections

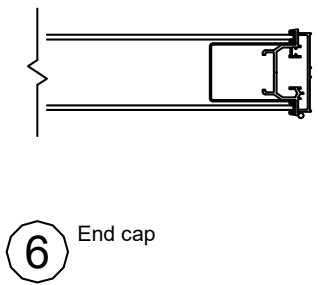
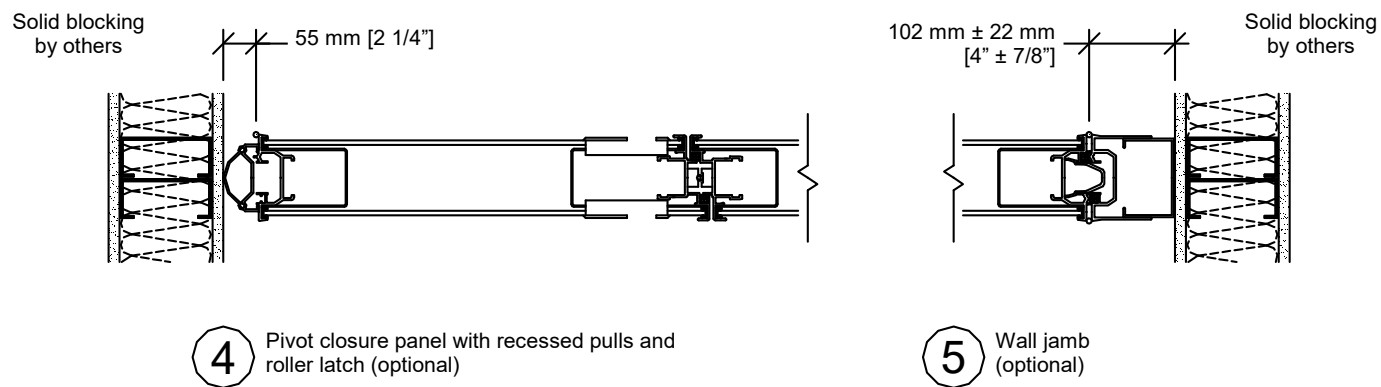
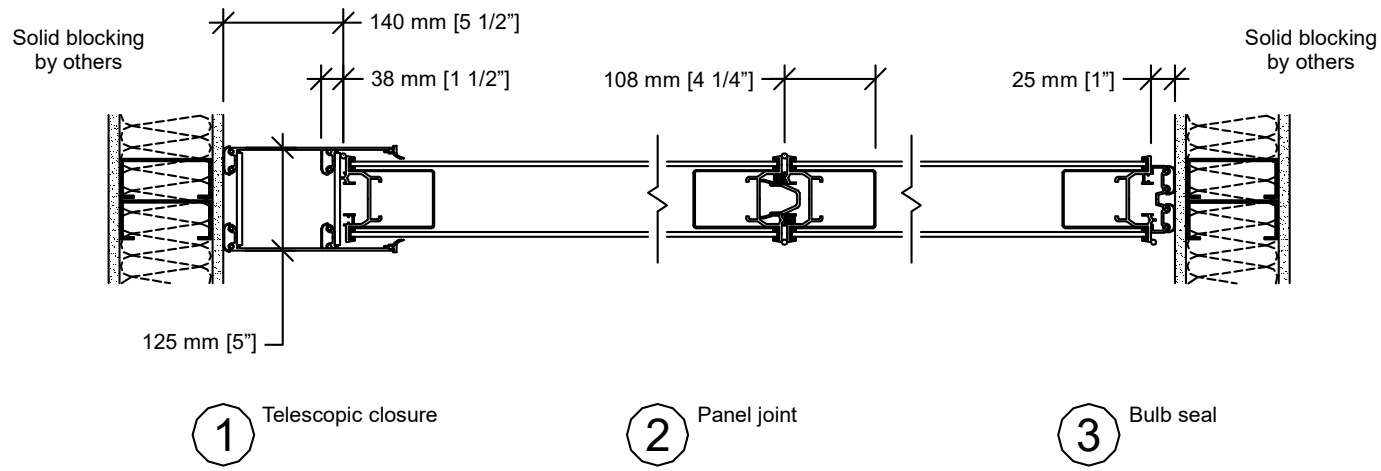



MODERCO

Typical Layouts

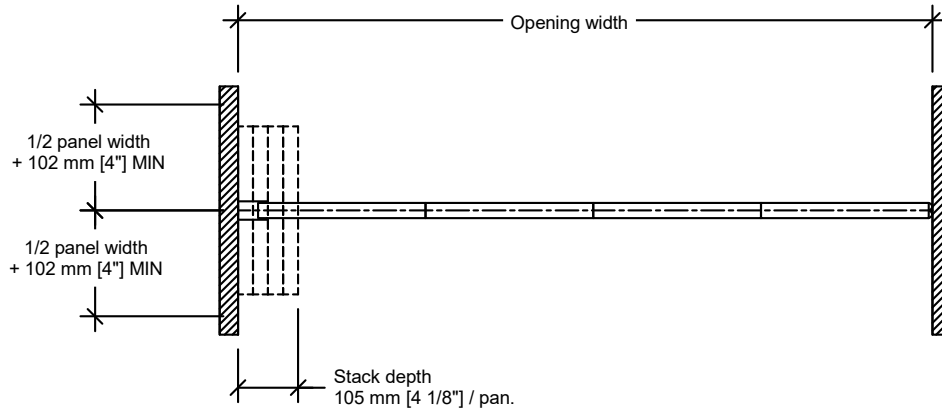

Wall to wall – telescopic closure

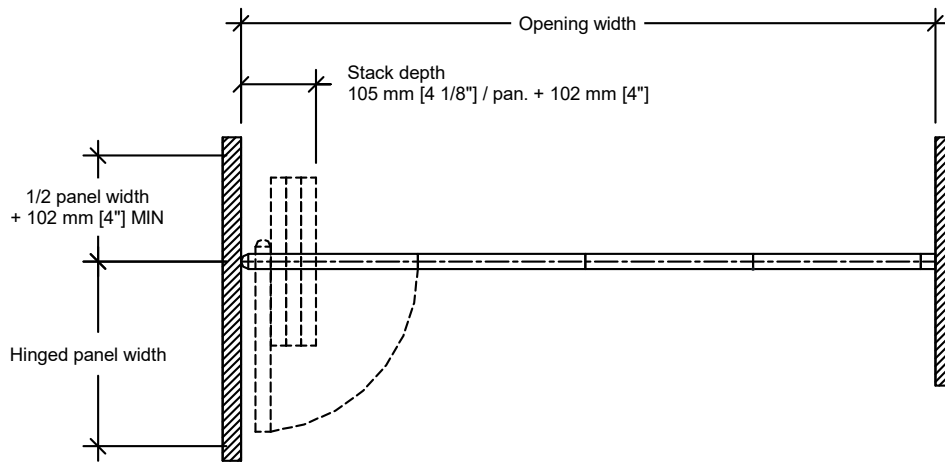

Wall to wall – pivot closure

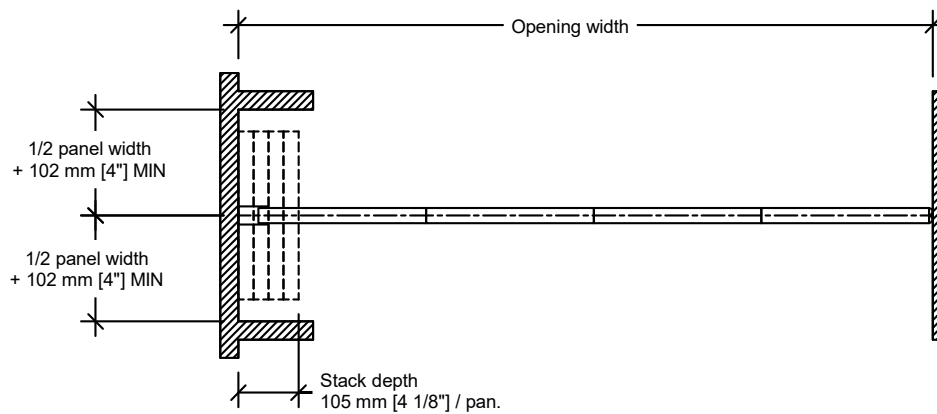

Pocket

Typical Layouts (cont'd)

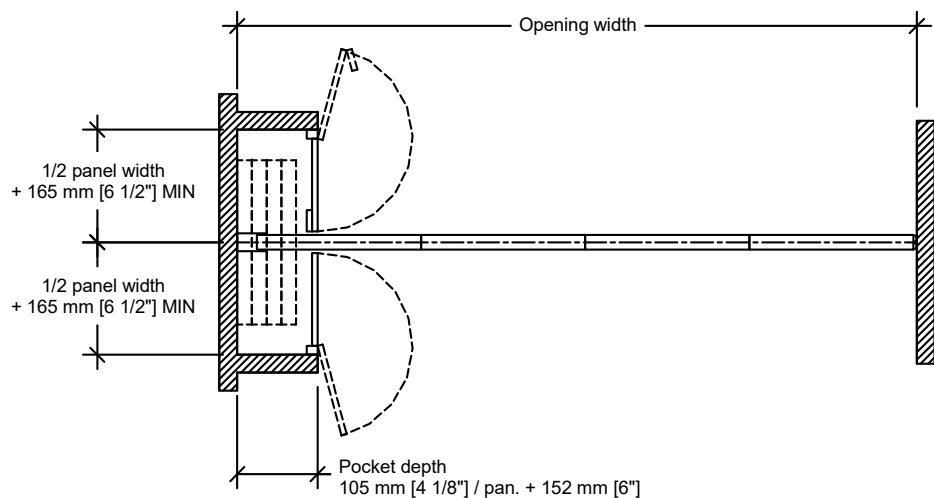

**Pocket and PN-3 non-acoustical pocket door
(partition seals to back of pocket)**

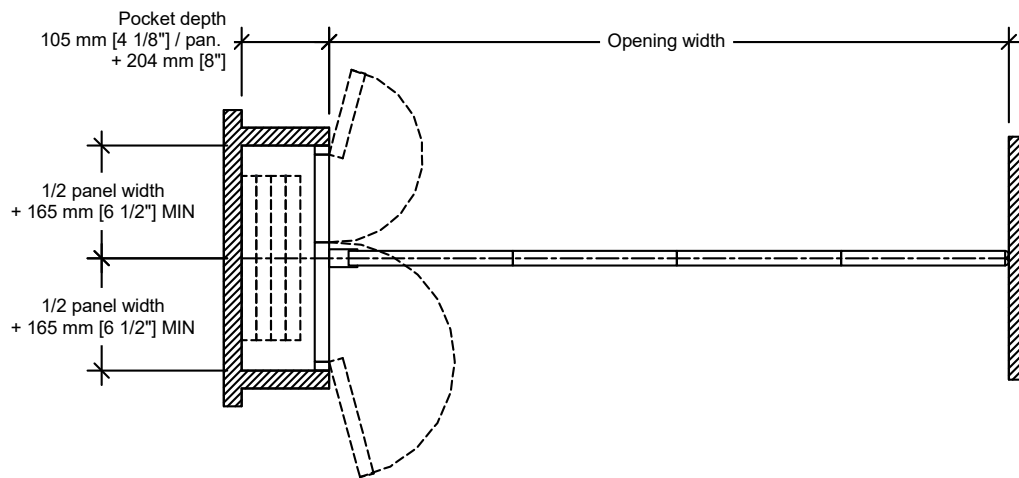

**Pocket and PA-2 acoustical pocket door
(partition seals to face of pocket door)**