

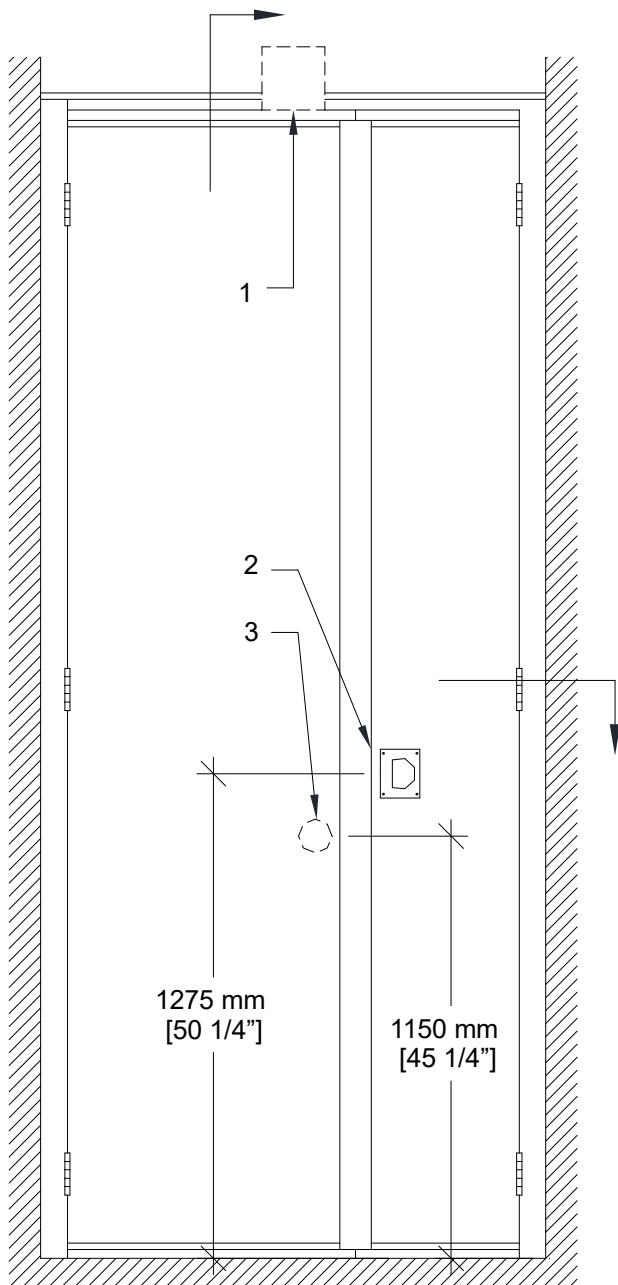

**MODERCO**

Excel 700 Series

## Technical Data Sheet Excel 700 PA-72 Pocket Door



### **PA-72 Acoustical Pocket Door**

- 2 independent sections
- Same core construction as movable partition panels
- Same surface finish as movable partition / optional custom finish / unfinished
- Same frame finish as movable partition / optional custom finish
- Fixed top and bottom sweeps
- Top and bottom locking bolts
- Full leaf butt hinges
- Optional deadbolt lock

- 1- Track
- 2- Flush pull
- 3- Top and bottom locking bolt activator (interior side)

**Vertical Section**

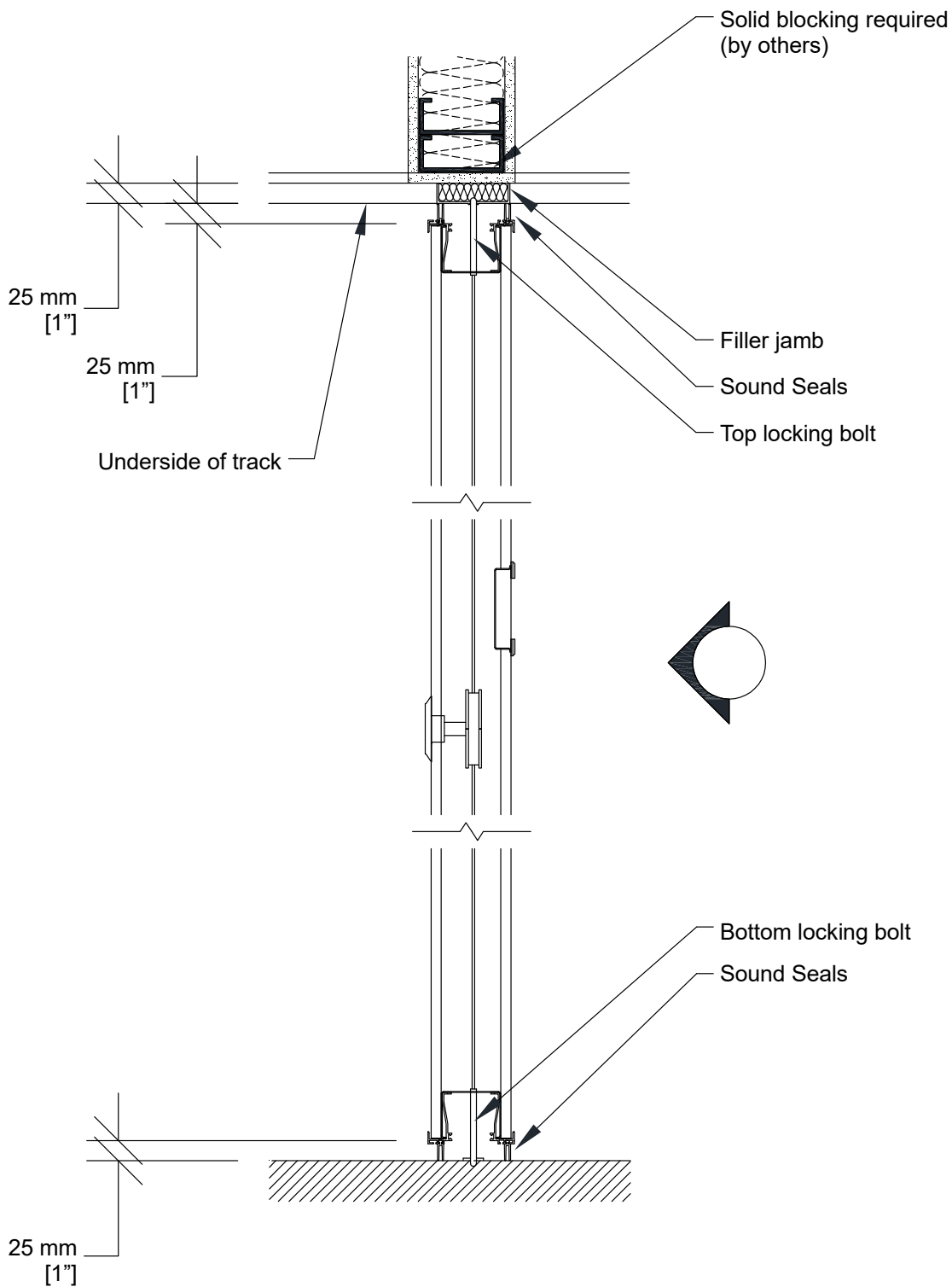

### Horizontal Section

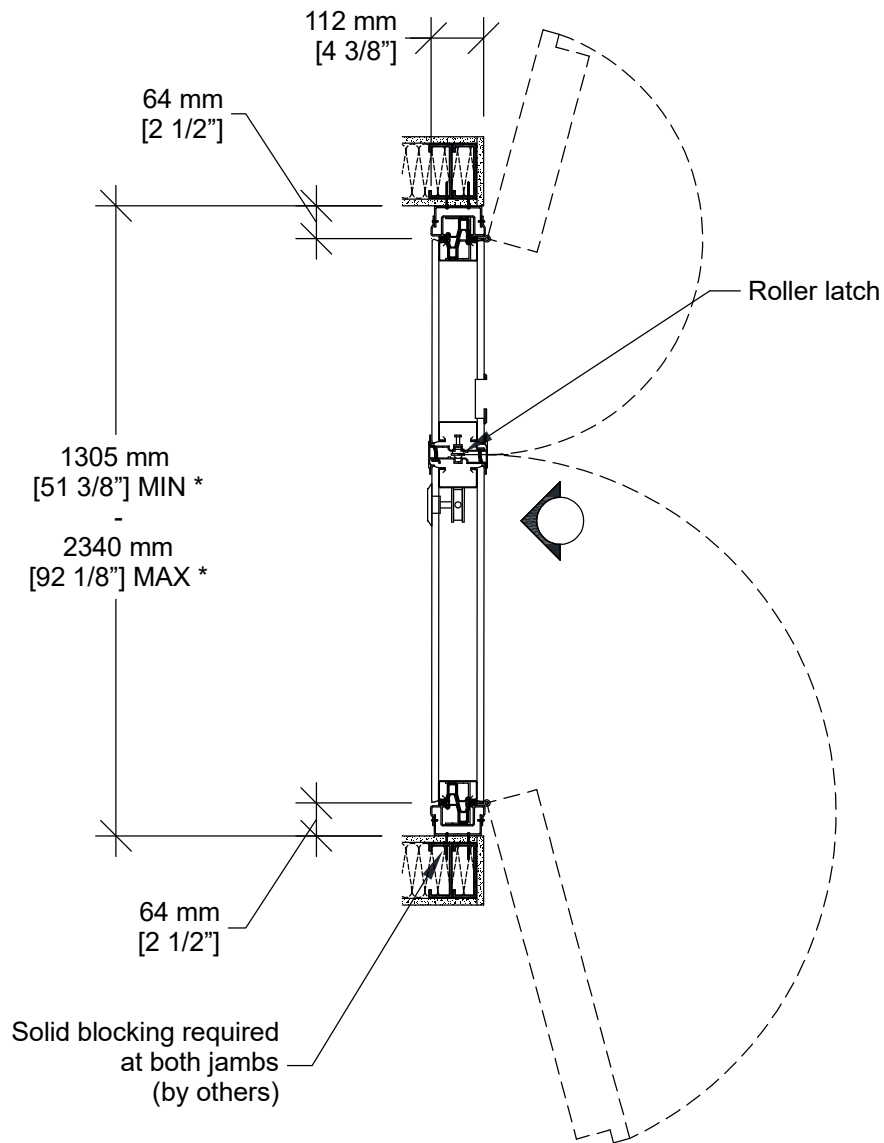

\* Min/Max dimensions are fabrication limits and do not account for job-specific conditions.

Please consult shop drawings or local Moderco distributor prior to sizing pockets.