

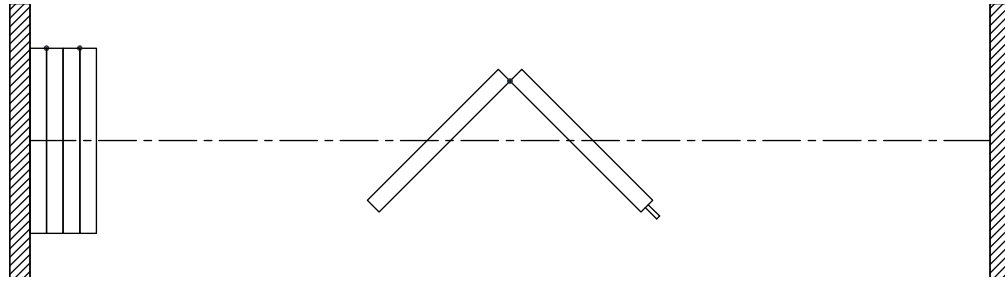

MODERCO

Excel 700 Series

Technical Data Sheet Excel 742



Features & Options

Standard Features

- Manually-operated paired-panel movable partition.
- STC 43, 48, 50, or 54.
- Steel faces laminated to gypsum board.
- 102 mm [4"] nominal thickness. 1230 mm [48 1/2"] maximum width.
- 18 ga. welded steel frame.
- Trimless vertical edges.
- Combination aluminum and vinyl tongue and groove vertical sound seals between panels.
- Final closure by telescopic jamb.
- Type FA horizontal seals :
 - Fixed top sweeps
 - Automatic retractable bottom seals set as panels are deployed
 - bottom seals provide a 50 mm [2"] floor clearance
- Steel butt hinges.

- Clear-anodized 6063-T6 alloy aluminum track.
- Each panel supported by one carrier made up of four vertically-aligned precision-ground hardened steel ball bearing wheels with nylon tires.

- Vinyl wallcovering.

- Maximum height: 4953 mm [16'-3"].

Optional Features and Accessories

- STC 43 with gypsum board faces.
- Protective trims on entire perimeter.
- Powder-coated frame and/or track.
- 11 ga. steel track, painted white.
- Upgraded wallcoverings : fabric, vertically-ribbed carpet, or full-height marker board.
- Owner-supplied wallcovering (approval required).
- Final closure by hinged closure panel.

Optional Features and Accessories (cont'd)

- ADA-compliant pass door with flush pulls and roller latch.
- Door options:
 - concealed automatic closer
 - window frame
 - door viewer
 - panic bar
 - panic bar with lockable lever
 - self-illuminated exit sign *
 - "green running man" self-illuminated exit sign *
 - deadbolt lock *

(* An exit sign and a deadbolt lock will not be installed together on the same door.)
- Surface-mounted white marker boards.
- Surface-mounted chalk boards.
- Surface-mounted natural cork tack boards.
- Eraser boxes.
- Acoustical or non-acoustical pocket door.

Horizontal Seals

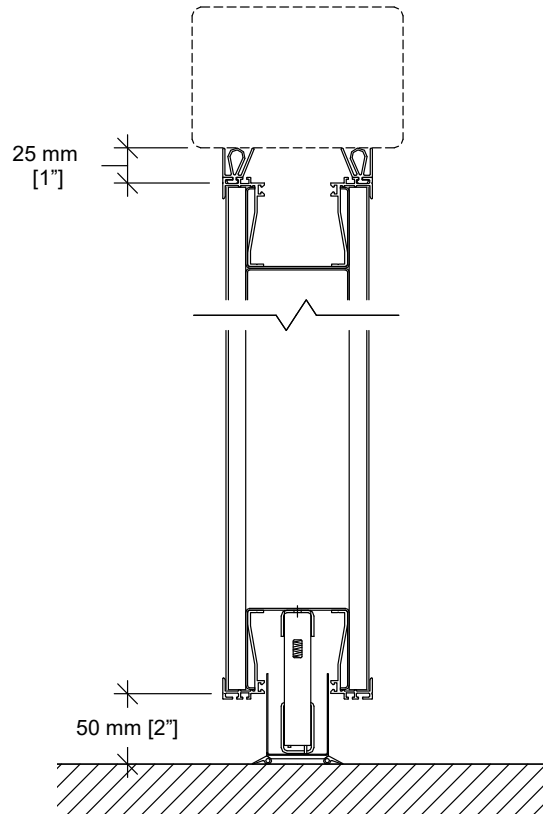

Type FA

Floor clearance : 50 mm [2"]
 Operating tolerances :
 +0 mm / -38 mm [+0" / -1 1/2"]



MODERCO

Vertical Section

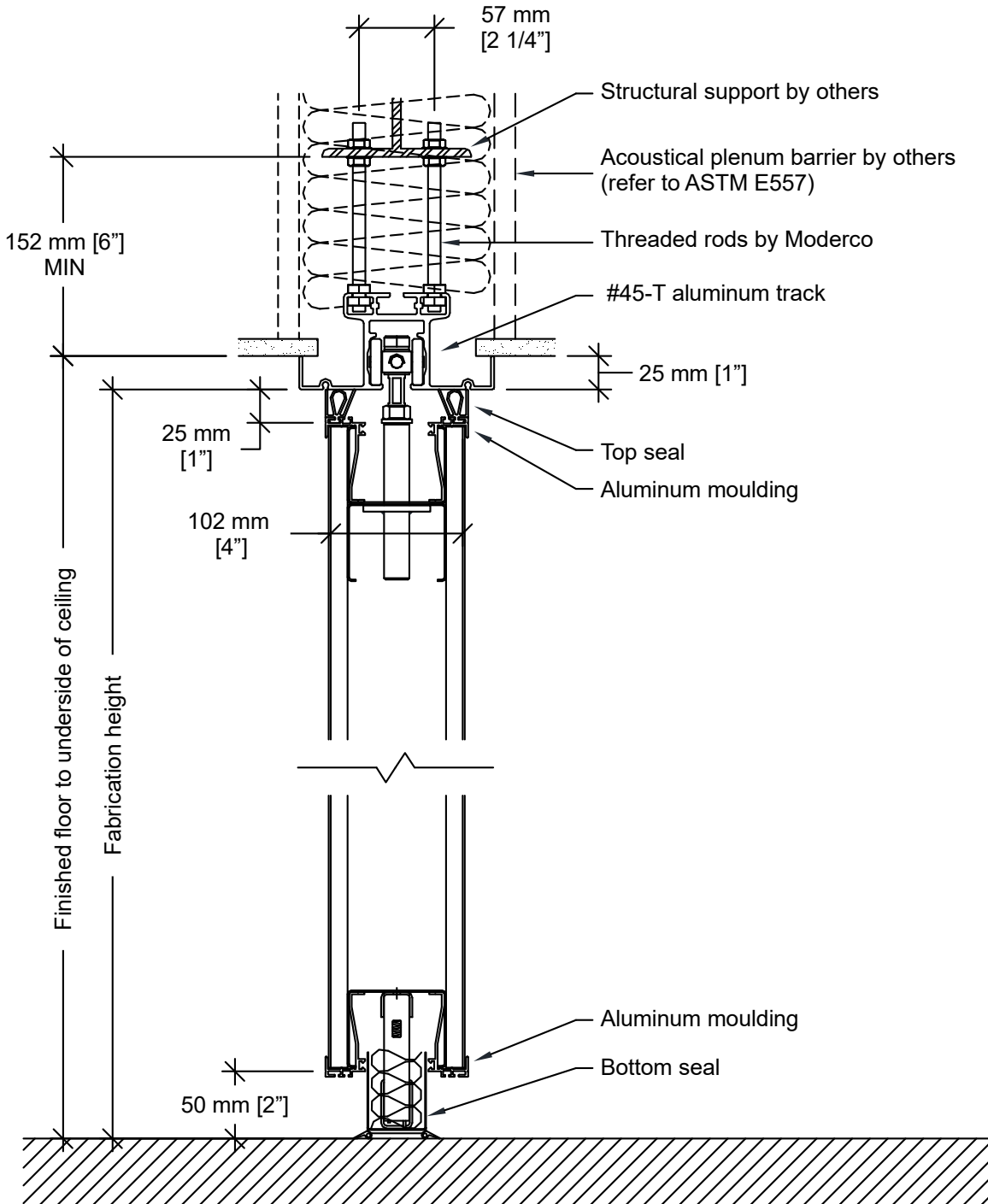

Track Options

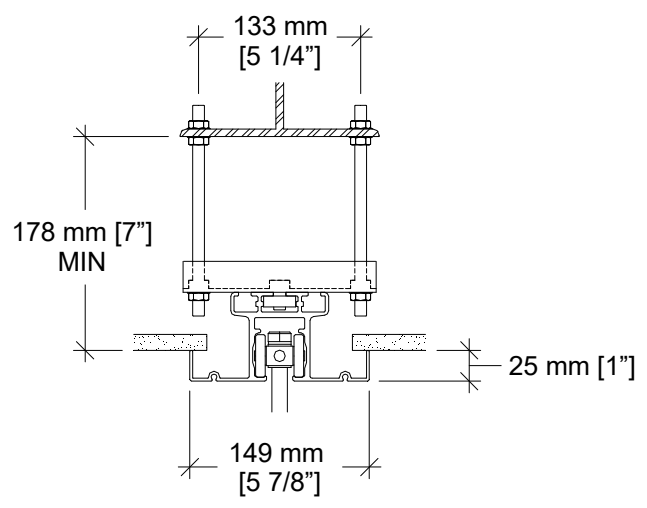

#45-T track with optional hanger bracket

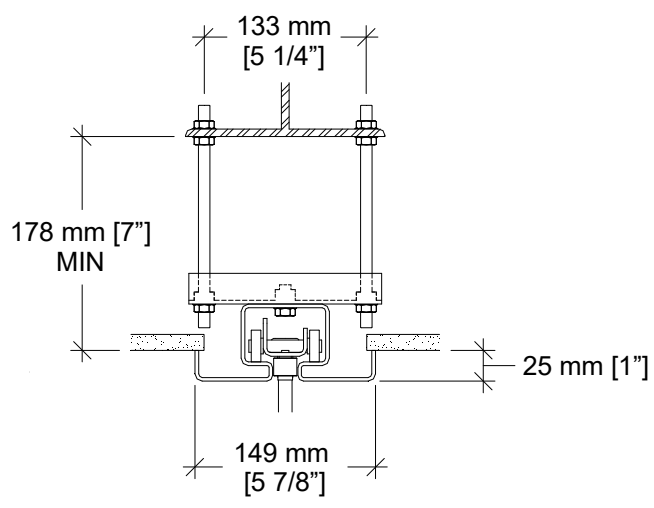

Optional #72 steel track with hanger bracket

Hanger bracket required for installations where the topmost nuts cannot be used for adjustment.

Elevation

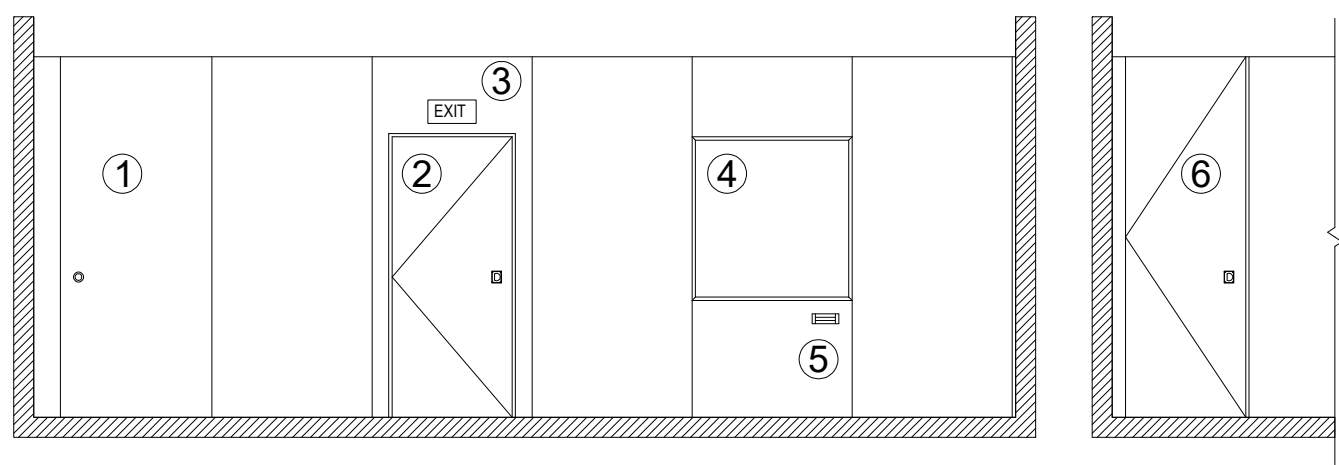

- 1- Telescopic closure panel
- 2- Single pass door
- 3- Self-illuminated exit sign
- 4- Work surface
- 5- Eraser box
- 6- Hinged closure panel

Plan Views

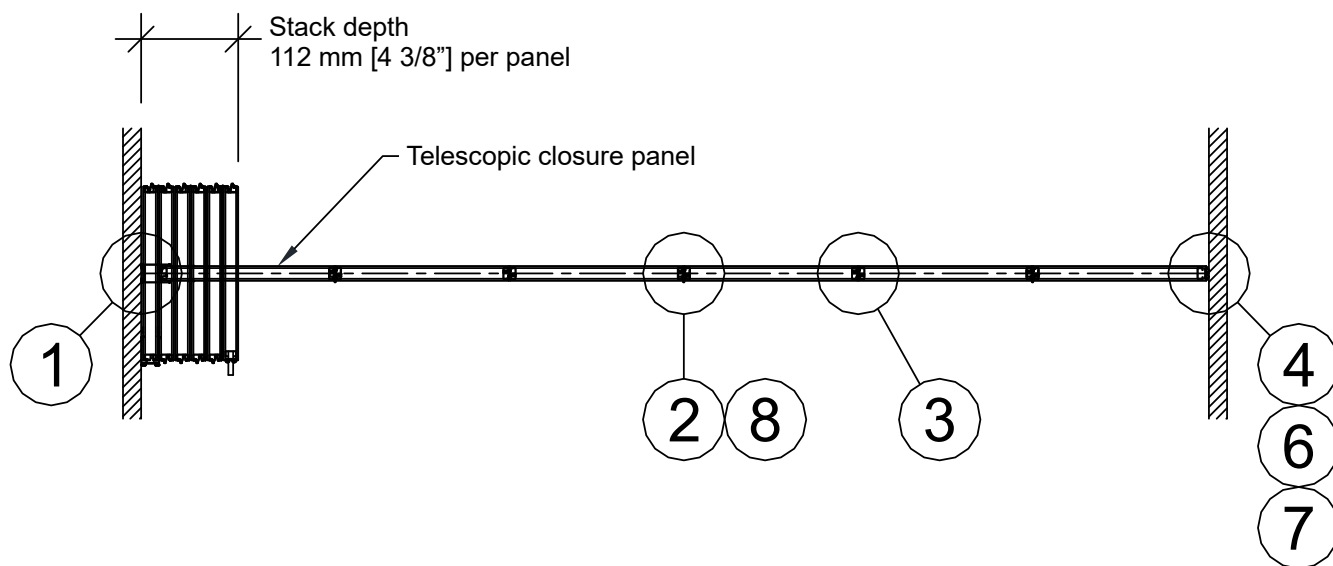

Telescopic closure panel

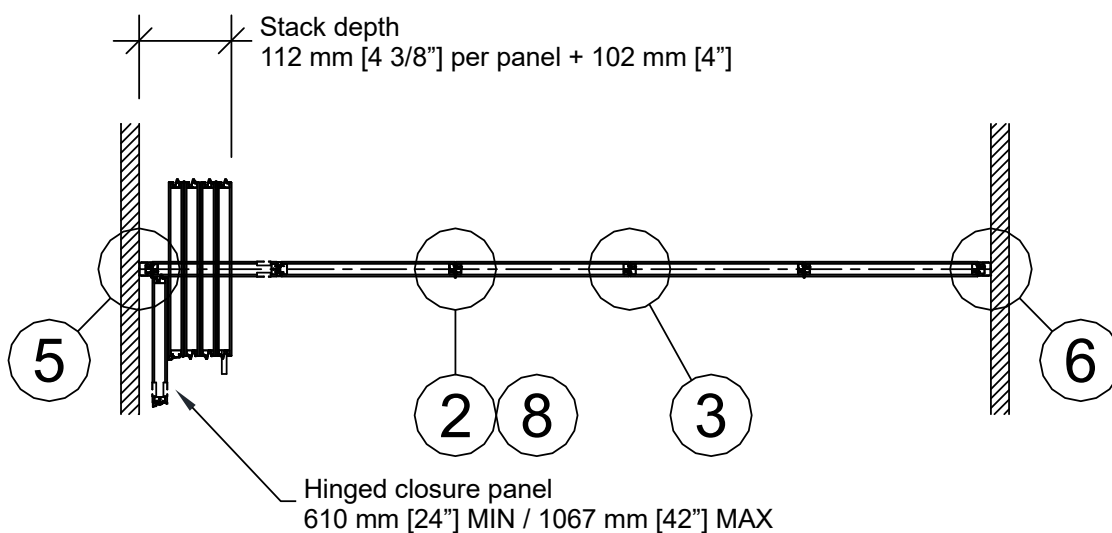

Hinged closure panel

Horizontal Sections

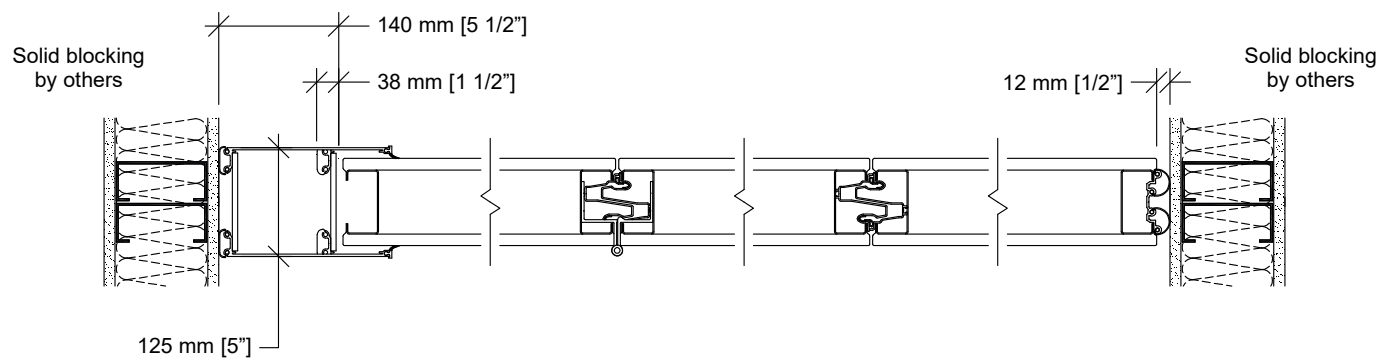

- ① Telescopic closure
- ② Hinged panel joint
- ③ Panel joint
- ④ Bulb seal

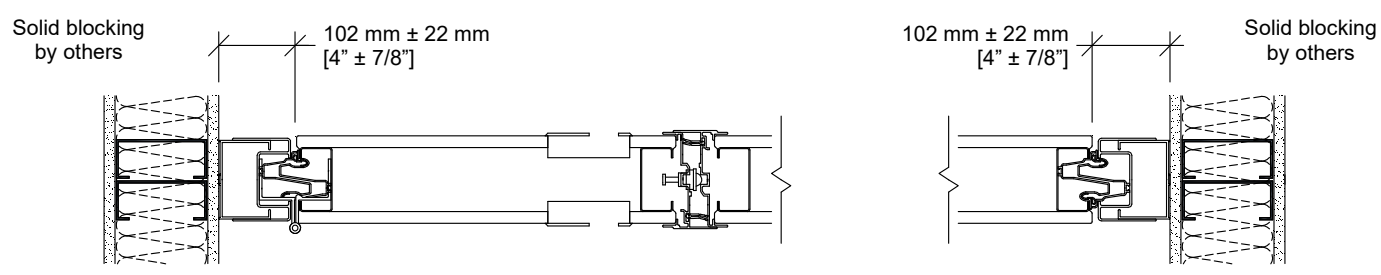

- ⑤ Hinged closure panel with recessed pulls and roller latch (optional)
- ⑥ Wall jamb (optional)

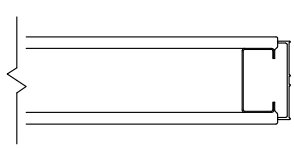

- ⑦ End cap (optional)

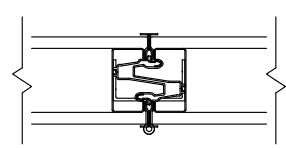

- ⑧ Panel joint with protective trims (optional)



MODERCO

Typical Layouts

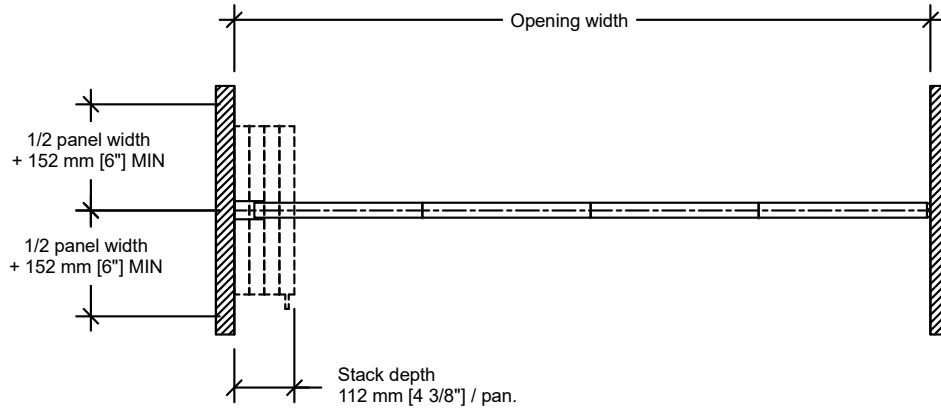

Wall to wall – telescopic closure

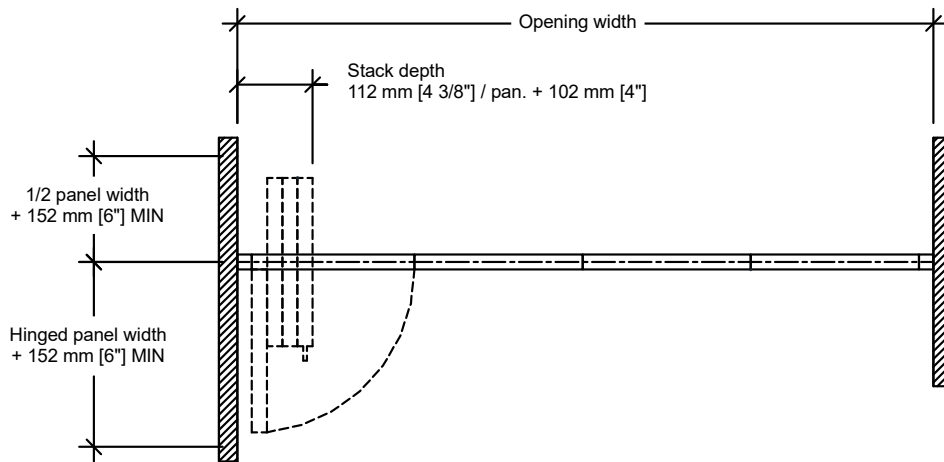

Wall to wall – hinged closure

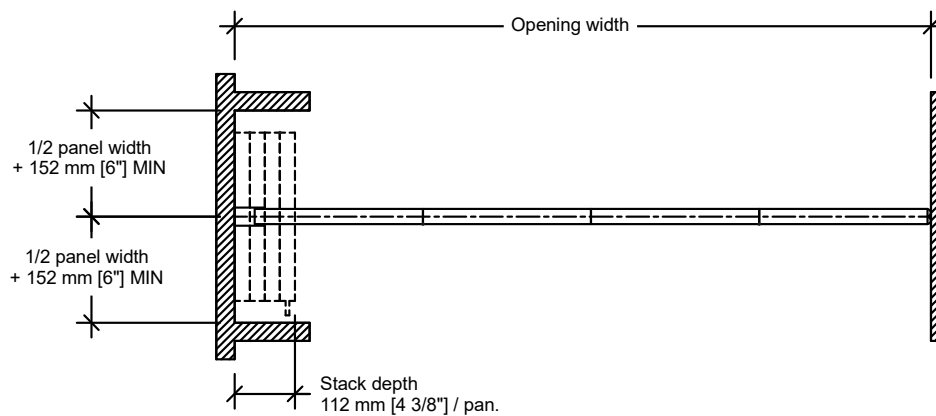

Pocket

Typical Layouts (cont'd)

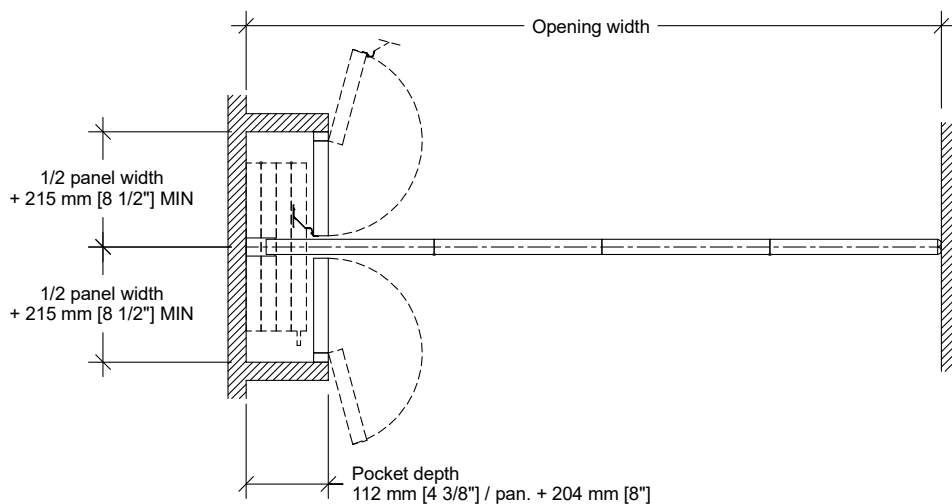

**Pocket and PN-73 non-acoustical pocket door
(partition seals to back of pocket)**

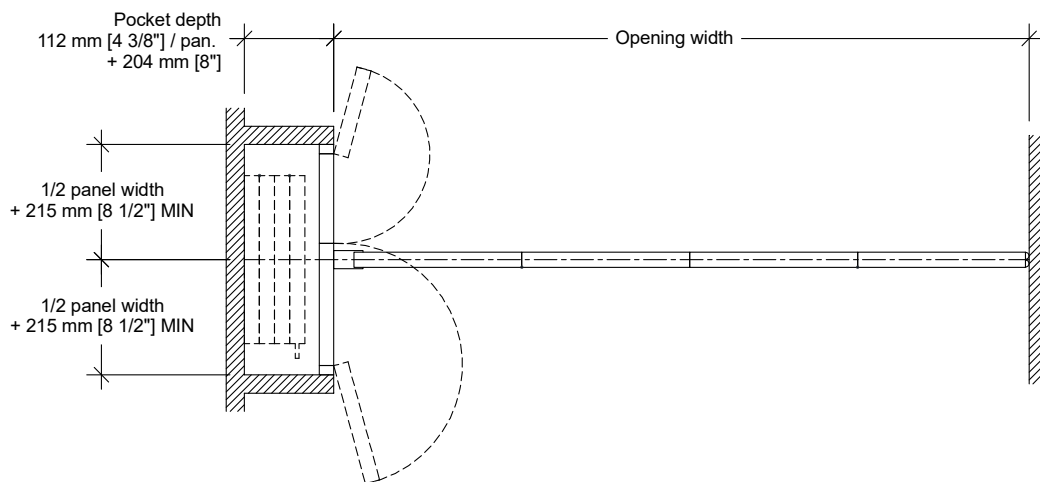

**Pocket and PA-72 acoustical pocket door
(partition seals to face of pocket door)**