

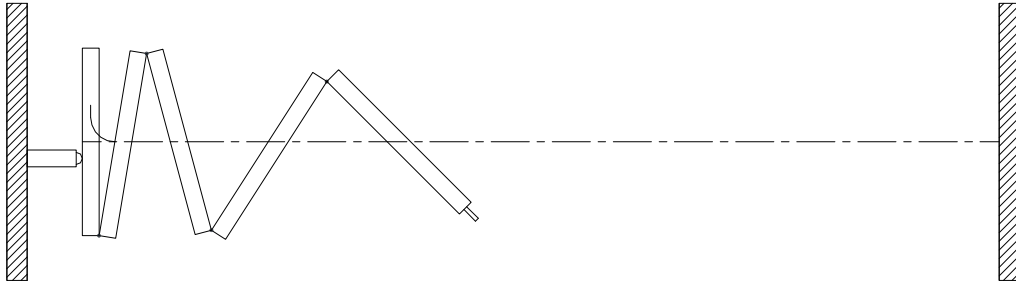

MODERCO

Excel 700 Series

Technical Data Sheet Excel 743-E



Features & Options

Standard Features

- Electrically-operated continuously-hinged movable partition.
- Driven with Ø5 mm [3/16"] steel cable.
- STC 43, 48, 50, or 54.
- Steel faces laminated to gypsum board.
- 102 mm [4"] nominal thickness. 1230 mm [48 1/2"] maximum width.
- 18 ga. welded steel frame.
- Trimless vertical edges.
- Combination aluminum and vinyl tongue and groove vertical sound seals between panels.
- Final closure by lateral wall jamb.
- Type FA horizontal seals :
 - Fixed top sweeps
 - Automatic retractable bottom seals set as panels are deployed
 - bottom seals provide a 50 mm [2"] floor clearance
- Steel butt hinges.
- Clear-anodized 6063-T6 alloy aluminum track.
- Odd-numbered panels supported by one 4-wheeled carrier with steel tires over hardened steel ball bearing wheels.
- Vinyl wallcovering.
- Maximum height: 3733 mm [12'-3"]
Maximum length: 19810 mm [65'-0"]
- UL/ULC listed drive unit with NEMA-1 motor enclosure and controls and control enclosure conform to ANSI/NEMA ICS1, ICS 2 and ICS 6.
- 1.5 hp / 120 V / 1 ph / 60 Hz
- Travel controlled by limit switches.
- Operation by two simultaneously-activated key switches located on each side of the partition.

Optional Features and Accessories

- Protective edge trims on the entire perimeter.
- Powder-coated protective trims and/or track.
- Upgraded wallcoverings : fabric, vertically-ribbed carpet, or full-height marker board.
- Owner-supplied wallcovering (approval required).
- Final closure at pocket door.

Optional Features and Accessories (cont'd)

- ADA-compliant pass door with flush pulls and roller latch.
- Door options:
 - concealed automatic closer
 - window frame
 - door viewer
 - self-luminescent exit sign with red (standard) or green (optional) faceplate *
 - “running man” self-luminescent exit sign with green faceplate *
 - deadbolt lock *

(An exit sign and a deadbolt lock will not be installed together on the same door.)*

- Surface-mounted white marker boards.
- Surface-mounted chalk boards.
- Surface-mounted natural cork tack boards.
- Eraser boxes.
- 3-section pocket door fitted with limit switches to prevent operation of the partition until the pocket door is fully opened.

Horizontal Seals

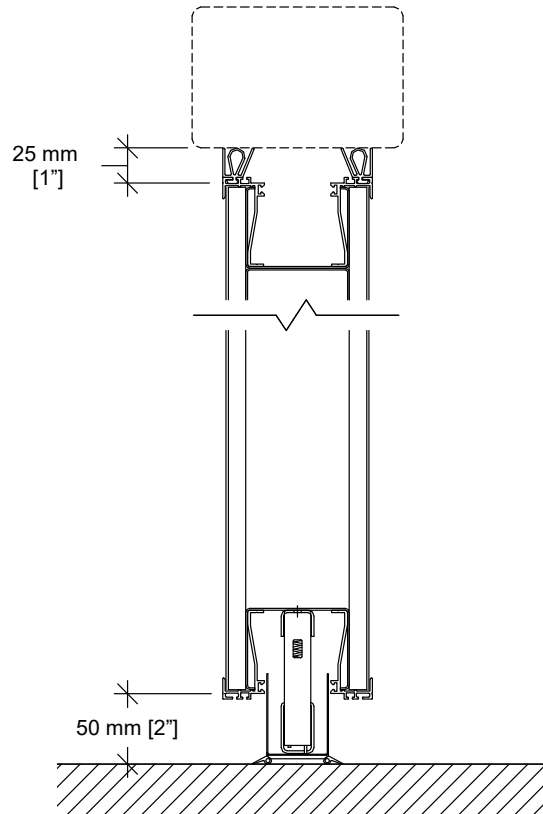

Type FA

Floor clearance : 50 mm [2"]

Operating tolerances :

+0 mm / -38 mm [+0" / -1 1/2"]



MODERCO

Vertical Section

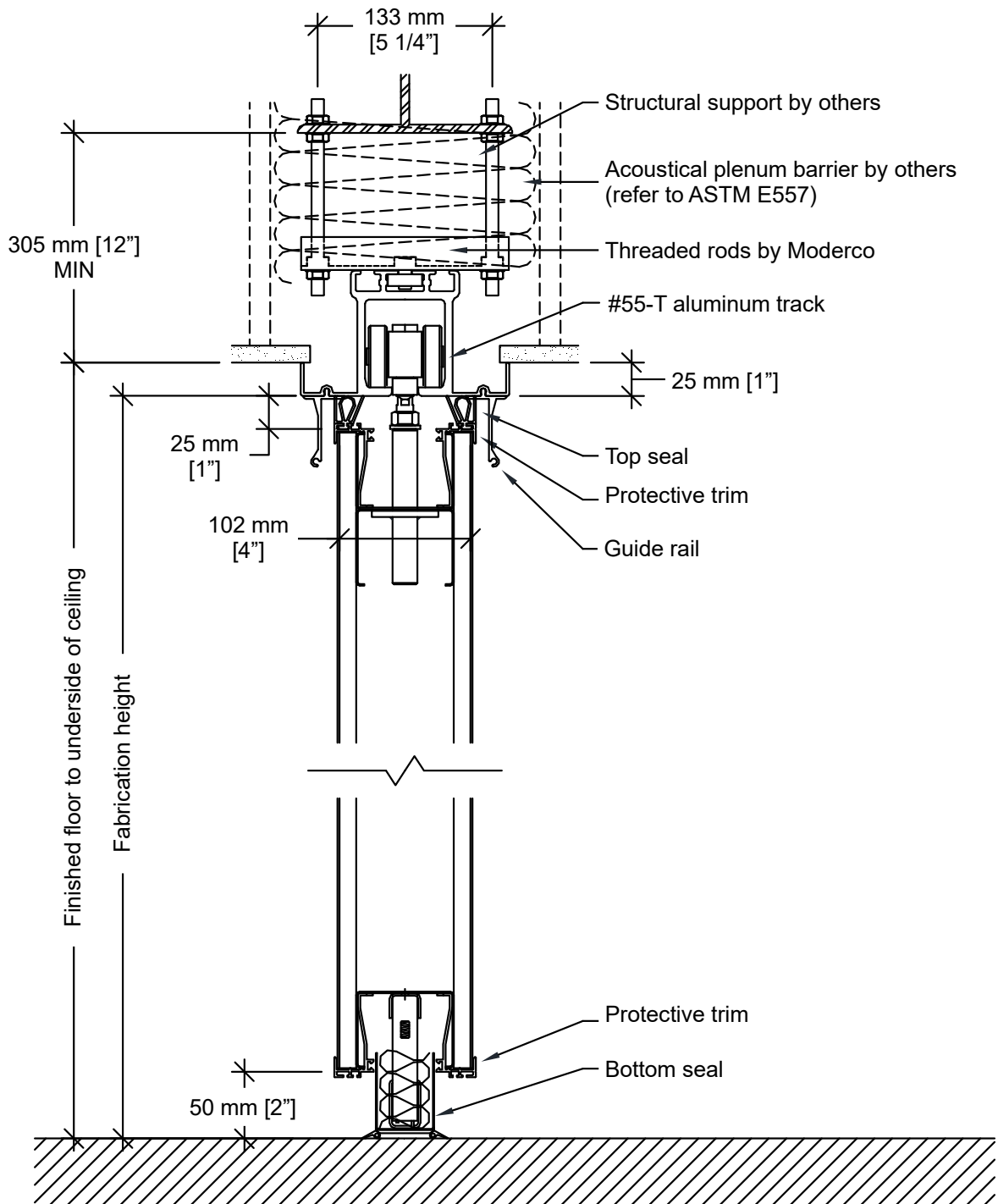

Elevation

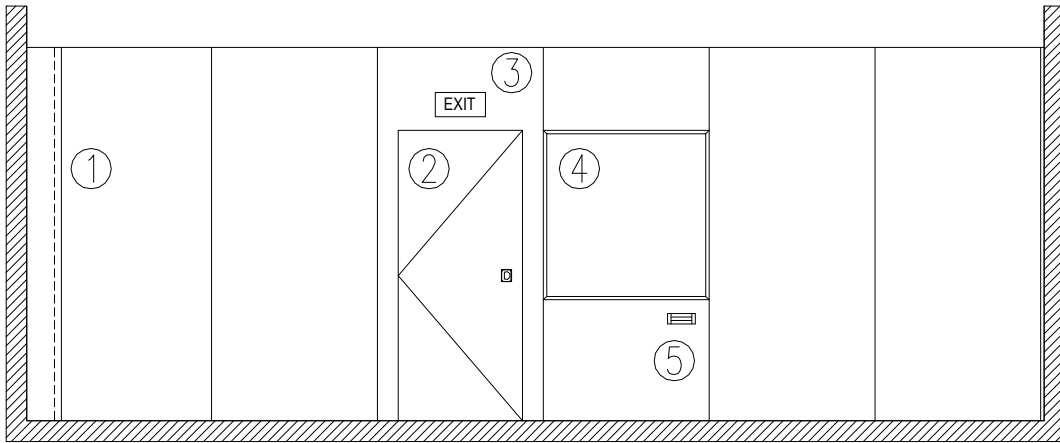

- | | |
|-------------------------------|-----------------|
| 1- Closure panel | 4- Work surface |
| 2- Single pass door | 5- Eraser box |
| 3- Self-illuminated exit sign | |

Plan Views

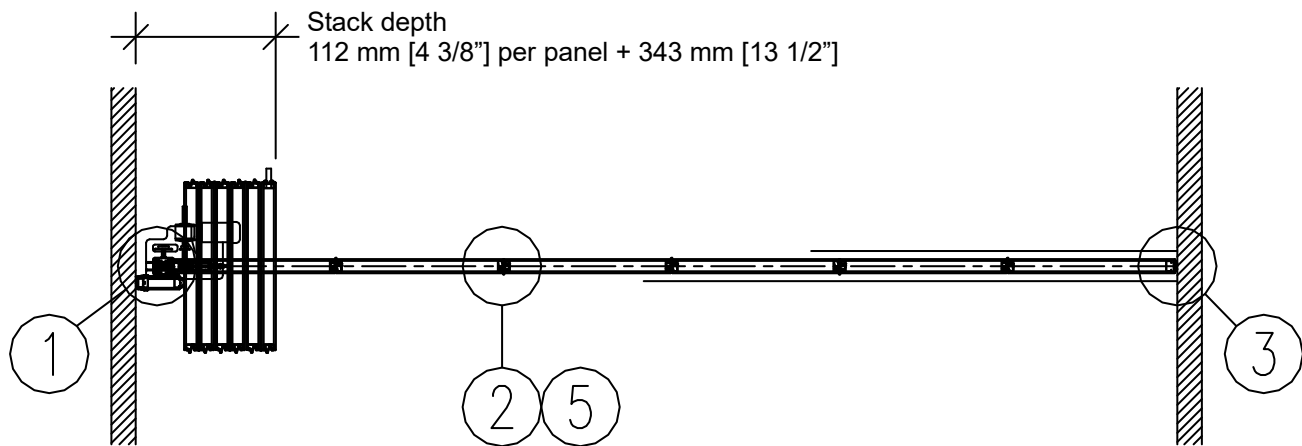

Wall to wall

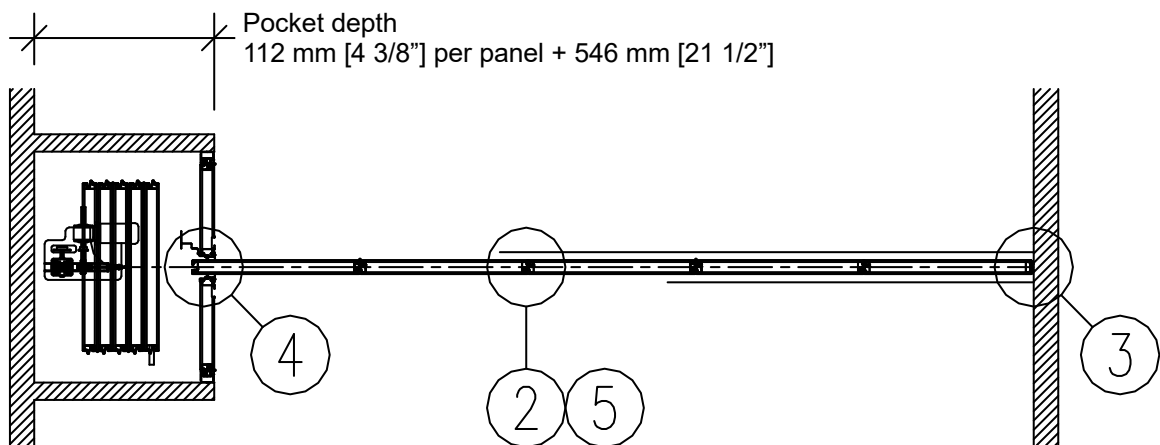

Wall to pocket with PA-73 acoustical pocket door

Horizontal Sections

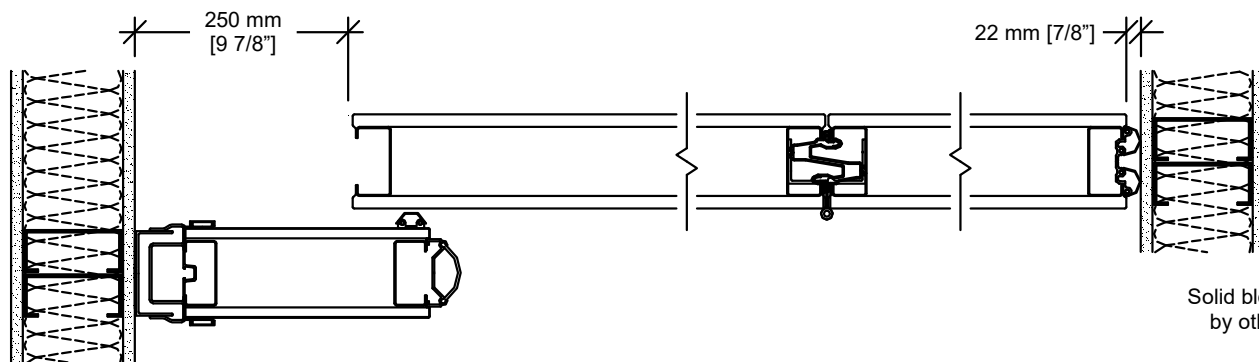

Solid blocking
by others



Side jamb closure



Panel joint



Bulb seal

Solid blocking
by others

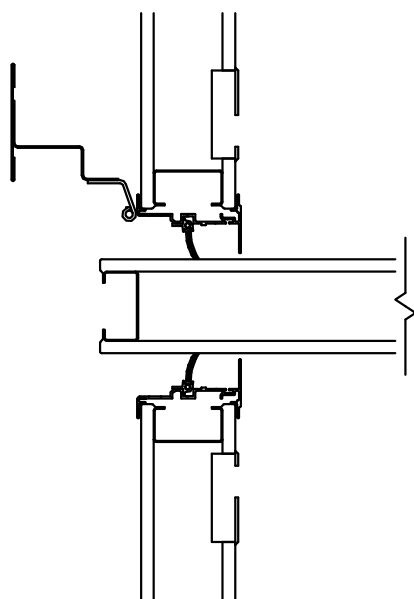

Closure at pocket door
(optional)

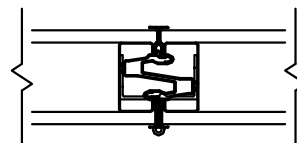

Panel joint with protective trims
(optional)

Drive Unit

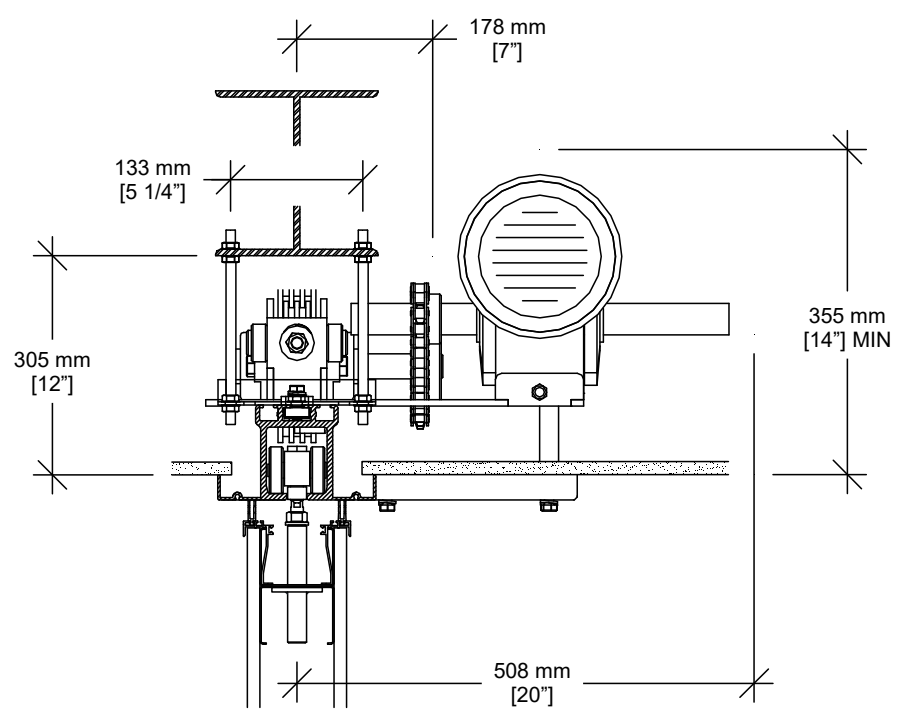

Optional Safety Devices

