

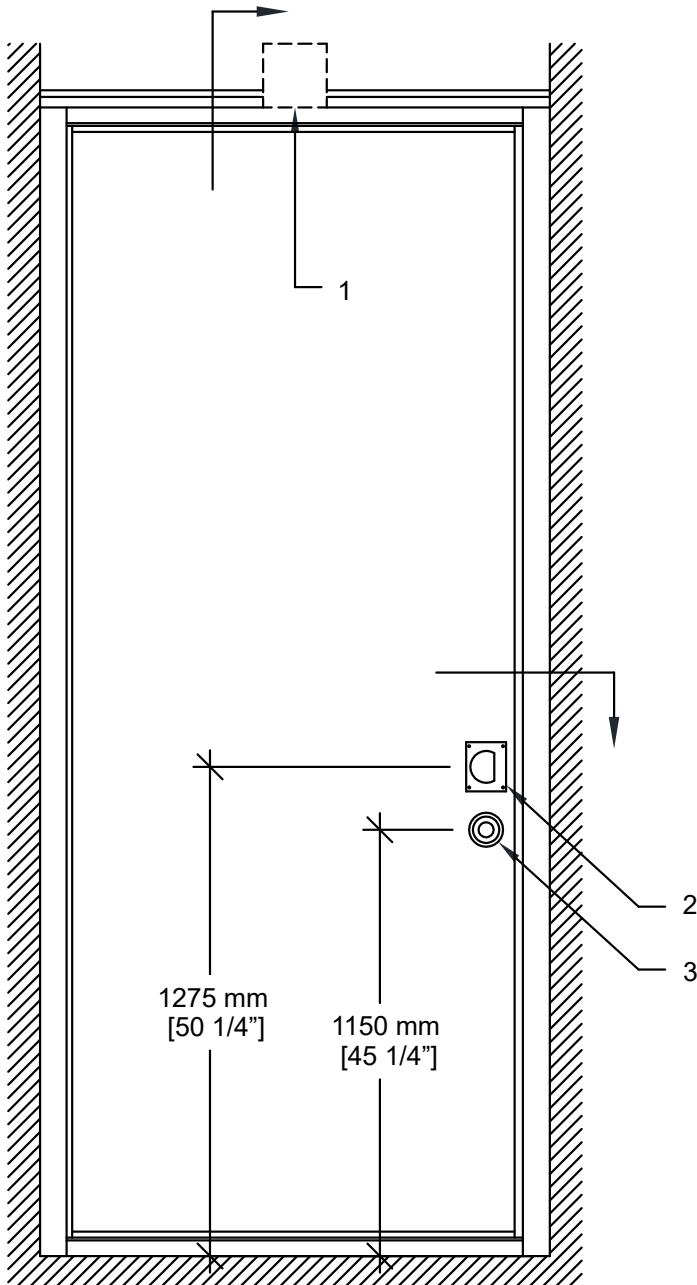

**MODERCO**

Signature 800 Series

## Technical Data Sheet Signature 800 PA-81 Pocket Door



### **PA-81 Acoustical Pocket Door**

- 1 section
- Same core construction as movable partition panels
- Same surface finish as movable partition / optional custom finish / unfinished
- Same frame finish as movable partition / optional custom finish
- Fixed top and bottom sweeps
- Top and bottom sliding bolts (if required by layout)
- Optional lock for top and bottom sliding bolts
- Low profile hinges

1- Track

2- Flush pull

3- Top and bottom sliding bolt activator

### Vertical Section

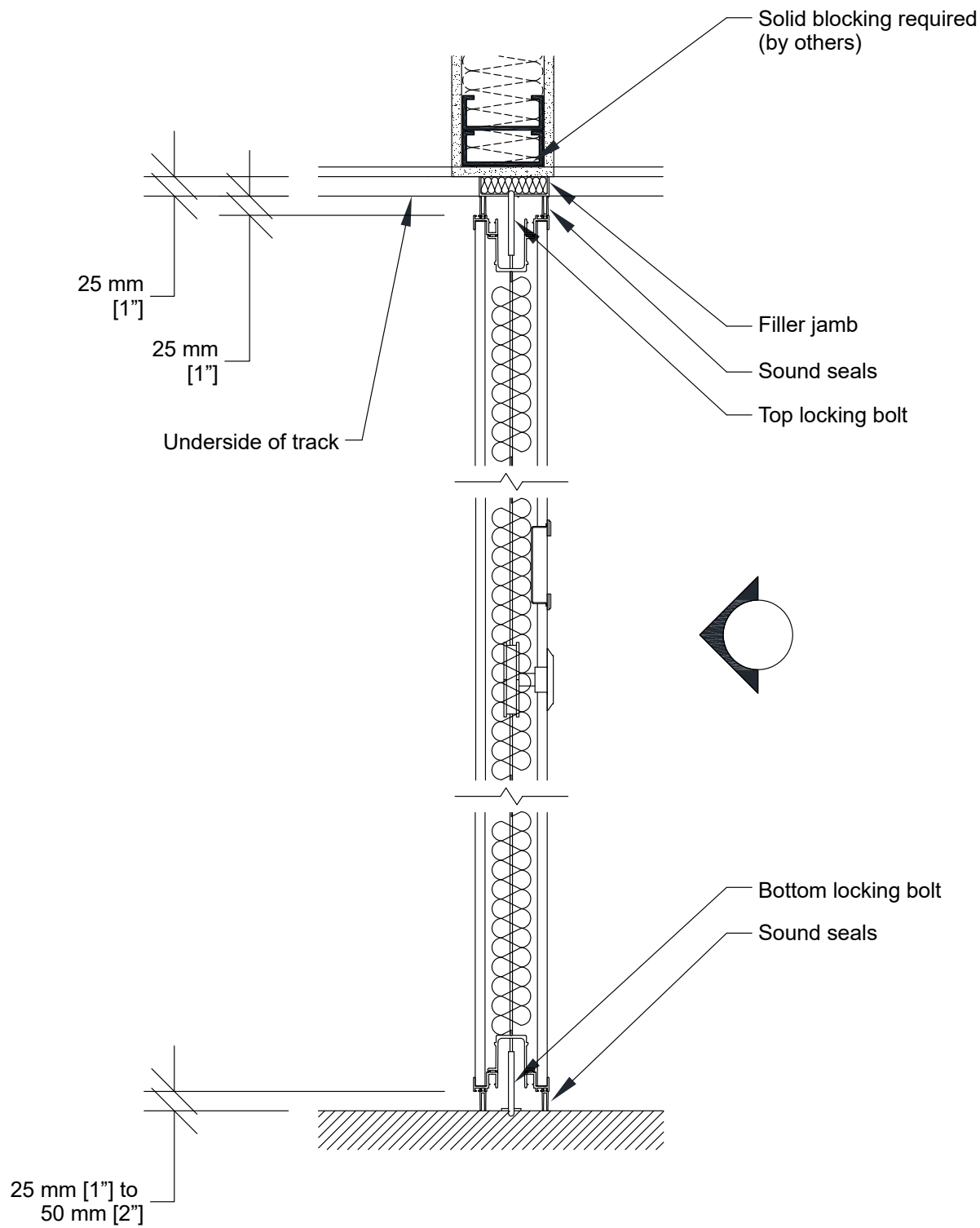

### Horizontal Section

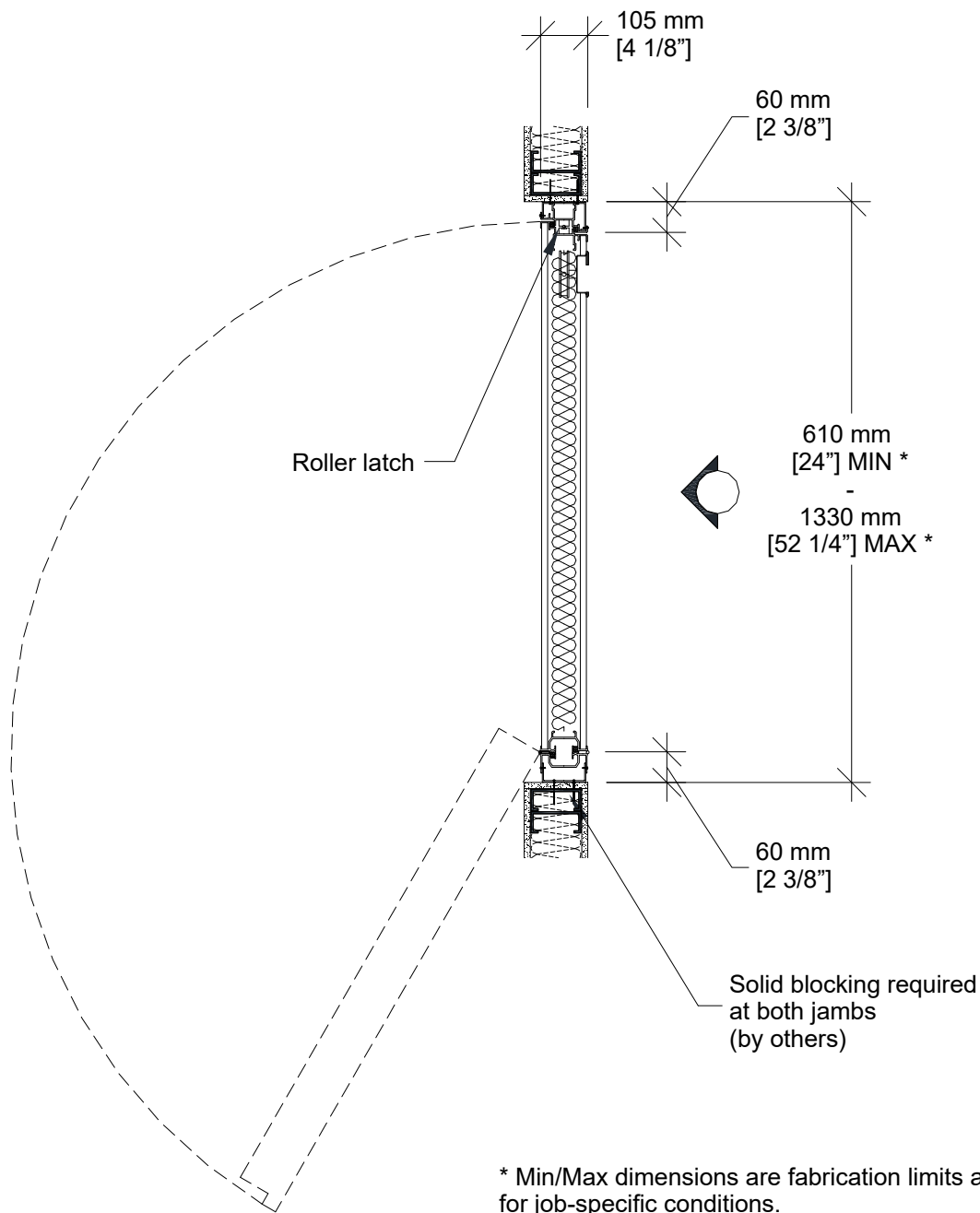

\* Min/Max dimensions are fabrication limits and do not account for job-specific conditions.

Please consult shop drawings or local Moderco distributor prior to sizing pockets.