

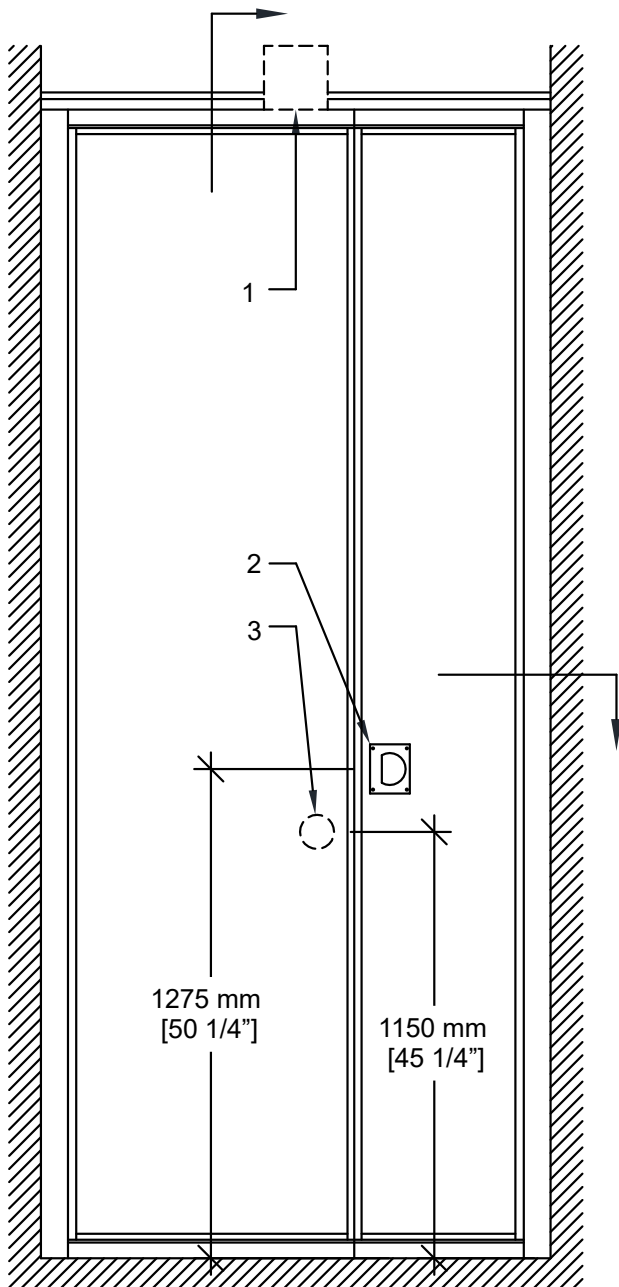

MODERCO

Signature 800 Series

Technical Data Sheet Signature 800 PA-82 Pocket Door



PA-82 Acoustical Pocket Door

- 2 independent sections
- Same core construction as movable partition panels
- Same surface finish as movable partition / optional custom finish / unfinished
- Same frame finish as movable partition / optional custom finish
- Fixed top and bottom sweeps
- Top and bottom sliding bolts
- Optional lock for top and bottom sliding bolts
- Low profile hinges
- Optional deadbolt lock

- 1- Track
- 2- Flush pull
- 3- Top and bottom sliding bolt activator

Vertical Section

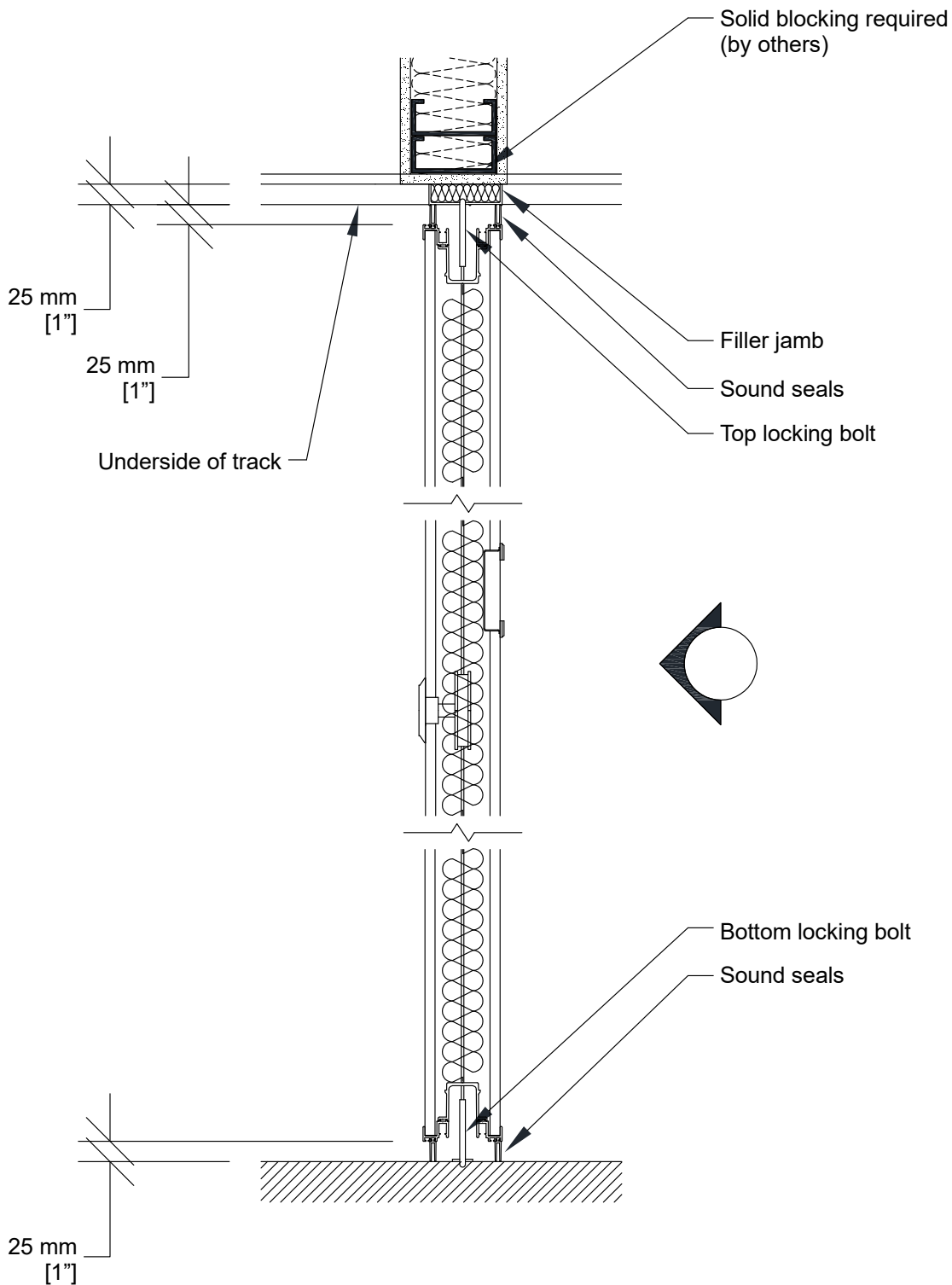

Horizontal Section

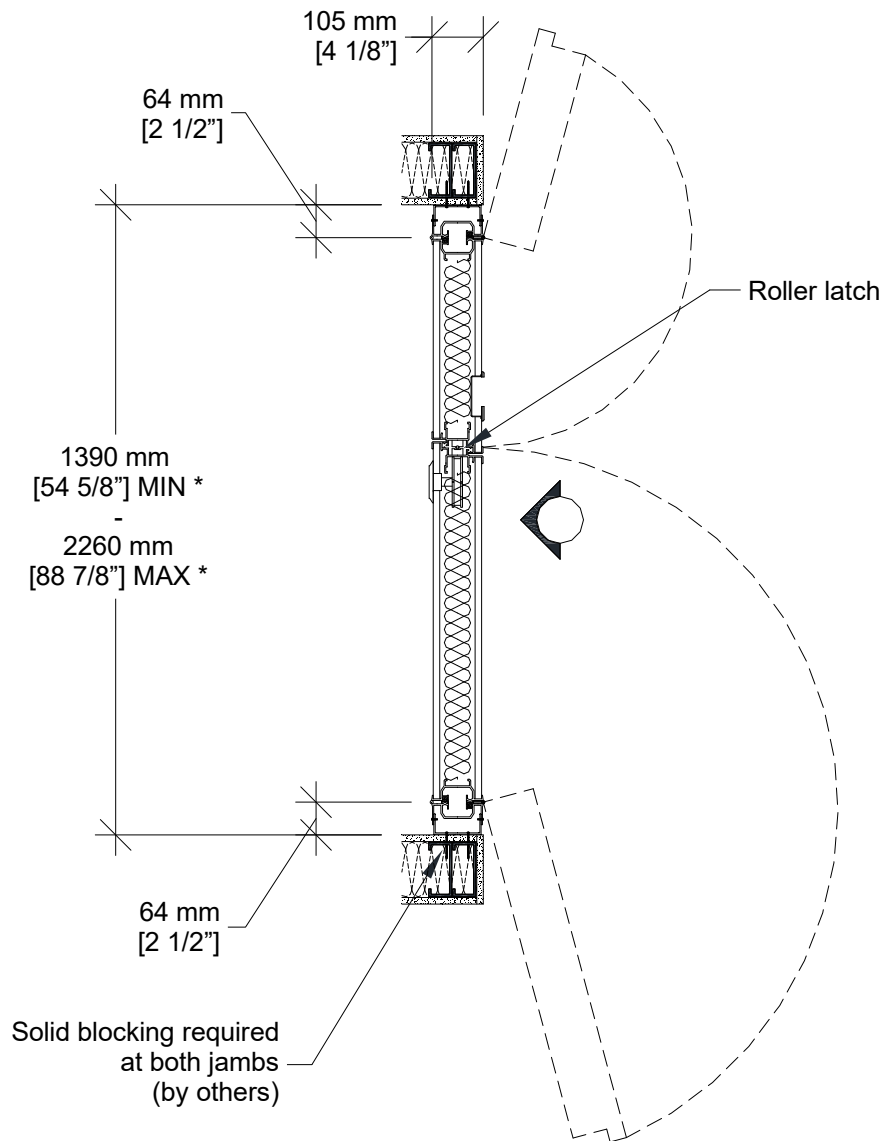

* Min/Max dimensions are fabrication limits and do not account for job-specific conditions.

Please consult shop drawings or local Moderco distributor prior to sizing pockets.