

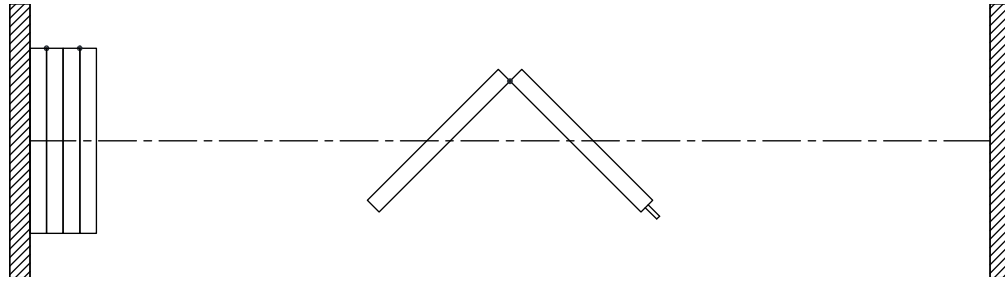

**MODERCO**

Signature 800 Series

## Technical Data Sheet Signature 842



### Features & Options

#### **Standard Features**

- Manually-operated paired-panel movable partition.
- STC 43 or 47 with gypsum board faces.
- STC 49, 52, 53, or 55 with steel faces laminated to gypsum board.
- 102 mm [4"] nominal thickness. 1230 mm [48 1/2"] maximum width.
- Clear-anodized steel-reinforced aluminum frame.
- Protective trims on entire perimeter.
- Combination aluminum and vinyl tongue and groove vertical sound seals between panels.
- Final closure by telescopic jamb.
- Type FA horizontal seals:
  - Fixed top sweeps
  - Automatic retractable bottom seals set as panels are deployed
  - bottom seals provide a 50 mm [2"] floor clearance
- (STC 53) Type MM-1 horizontal seals:
  - top and bottom retractable seals
  - Manually-operated, simultaneously-activated top and bottom seals
  - bottom seals provide a 25 mm [1"] floor clearance

- (STC 55) Type MM-55 horizontal seals:
  - top and bottom retractable seals
  - Manually-operated, simultaneously-activated top and bottom seals
  - bottom seals provide a 25 mm [1"] floor clearance
  - additional fixed top sweeps
- Low profile steel hinges.
- Clear-anodized 6063-T6 alloy aluminum track.
- Each panel supported by one carrier made up of four vertically-aligned precision-ground hardened steel ball bearing wheels with nylon tires.
- Vinyl wallcovering.

#### **Optional Features and Accessories**

- STC 49, 52, 53, or 55 with gypsum board faces and steel backing.
- Trimless vertical edges.
- Powder-coated frame and/or track.
- 11 ga. steel track, painted white.
- Upgraded wallcoverings: fabric, vertically-ribbed carpet, plastic laminate, full-height marker board, wood veneer, custom finishes.
- Owner-supplied wallcovering (approval required).

**Optional Features and Accessories (cont'd)**

- Final closure by hinged closure panel.
- (STC 43 to 52) Type FM horizontal seals:
  - Fixed top sweeps
  - Manually-operated bottom seals
  - bottom seals provide a floor clearance of 25 mm [1"], 38 mm [1 1/2"], 50 mm [2"], 64 mm [2 1/2"], or 102 mm [4"]
- (STC 43 to 52) Type MM horizontal seals:
  - top and bottom retractable seals
  - Manually-operated, simultaneously-activated top and bottom seals
  - bottom seals provide a floor clearance of 25 mm [1"], 38 mm [1 1/2"], 50 mm [2"], 64 mm [2 1/2"], or 102 mm [4"]
- (STC 43 to 52) Type AA horizontal seals:
  - top and bottom retractable seals
  - simultaneously-activated Automatic top and bottom seals
  - bottom seals provide a floor clearance of 38 mm [1 1/2"]
  - simultaneous operation of telescopic closure and seals of last panel / last pair of panels (also available on partitions with type MM-1.5 horizontal seals)
- ADA-compliant pass door with flush pulls and roller latch.
- Door options:
  - concealed automatic closer
  - window frame
  - door viewer
  - panic bar
  - panic bar with lockable lever
  - self-illuminated exit sign \*
  - "green running man" self-illuminated exit sign \*
  - deadbolt lock \*

(\* An exit sign and a deadbolt lock will not be installed together on the same door.)
- Inset white marker boards / chalk boards / natural cork tack boards.
- Eraser boxes / chalk trays
- Acoustical or non-acoustical pocket door.
- UL/ULC-listed 1 hour fire-rating (requires type MM-1, MM-1.5, or MM-2 horizontal seals).

**Horizontal Seals**

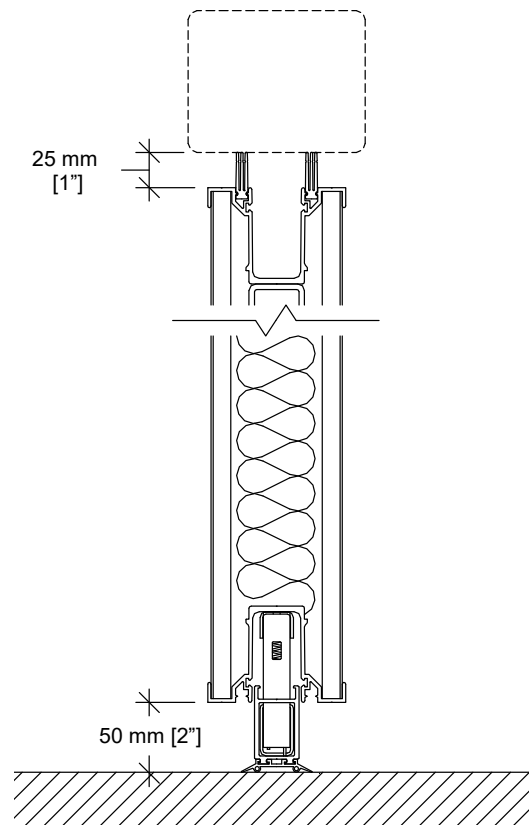

**Type FA**

Floor clearance : 50 mm [2"]  
 Operating tolerances :  
 +0 mm / -38 mm [+0" / -1 1/2"]

## Horizontal Seals (cont'd)

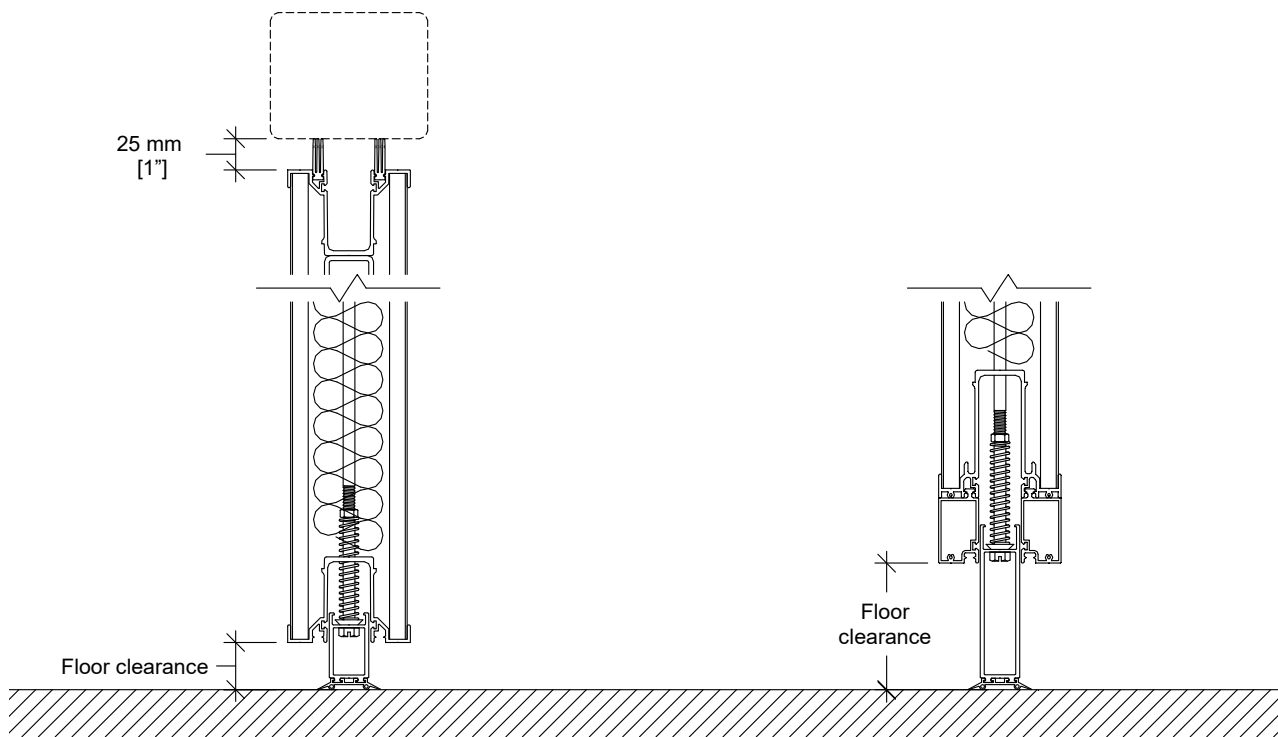

### Type FM-1

Floor clearance : 25 mm [1"]  
 Operating tolerances :  
 +0 mm / -15 mm [+0" / -5/8"]

### Type FM-1.5

Floor clearance : 38 mm [1 1/2"]  
 Operating tolerances :  
 +0 mm / -19 mm [+0" / -3/4"]

### Type FM-2

Floor clearance : 50 mm [2"]  
 Operating tolerances :  
 +0 mm / -25 mm [+0" / -1"]

### Type FM-2.5

Floor clearance : 64 mm [2 1/2"]  
 Operating tolerances :  
 +0 mm / -50 mm [+0" / -2"]

### Type FM-4

Floor clearance : 102 mm [4"]  
 Operating tolerances :  
 +0 mm / -89 mm [+0" / -3 1/2"]

### Horizontal Seals (cont'd)

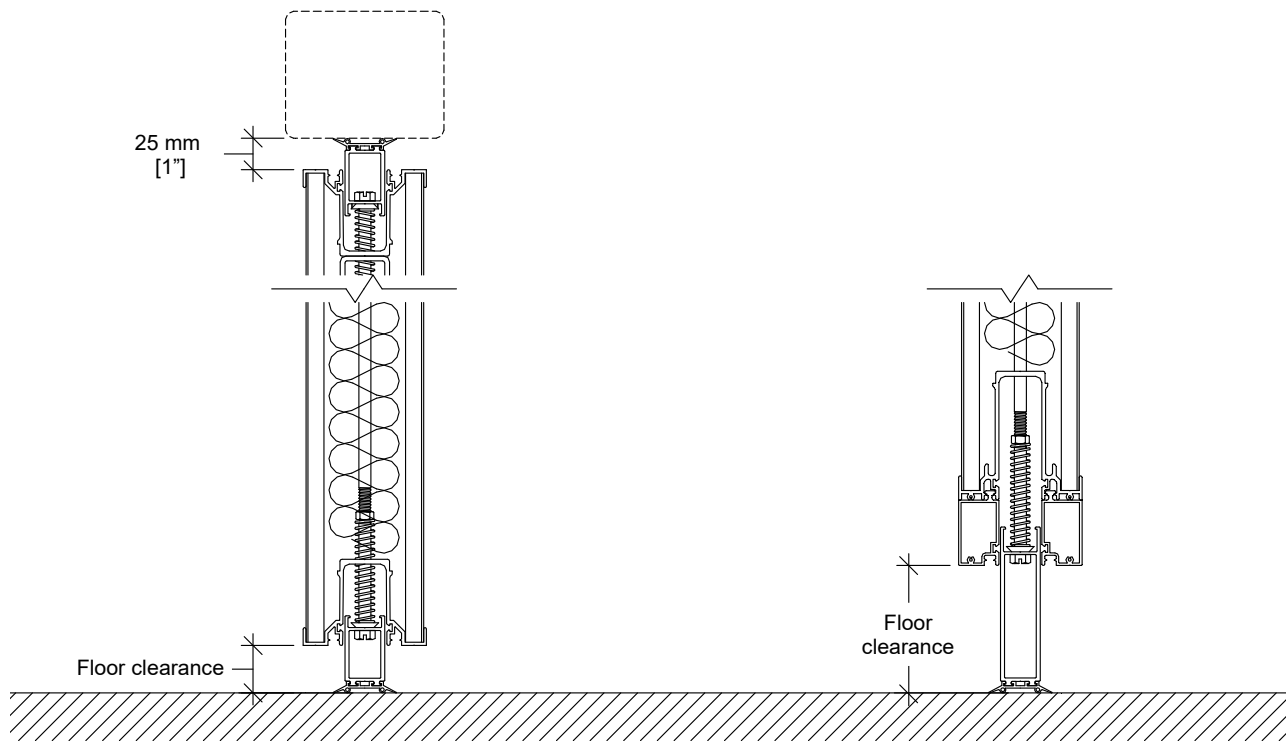

**Type MM-1**

Floor clearance : 25 mm [1"]  
 Operating tolerances :  
 +0 mm / -15 mm [+0" / -5/8"]

**Type MM-1.5**

Floor clearance : 38 mm [1 1/2"]  
 Operating tolerances :  
 +0 mm / -19 mm [+0" / -3/4"]

**Type MM-2**

Floor clearance : 50 mm [2"]  
 Operating tolerances :  
 +0 mm / -25 mm [+0" / -1"]

**Type MM-2.5**

Floor clearance : 64 mm [2 1/2"]  
 Operating tolerances :  
 +0 mm / -50 mm [+0" / -2"]

**Type MM-4**

Floor clearance : 102 mm [4"]  
 Operating tolerances :  
 +0 mm / -89 mm [+0" / -3 1/2"]

### Horizontal Seals (cont'd)

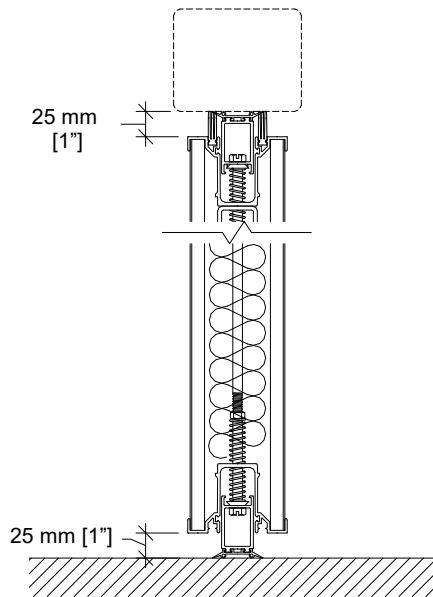

**Type MM-55 (STC 55 only)**  
 Floor clearance : 25 mm [1"]  
 Operating tolerances :  
 +0 mm / -15 mm [+0" / -5/8"]

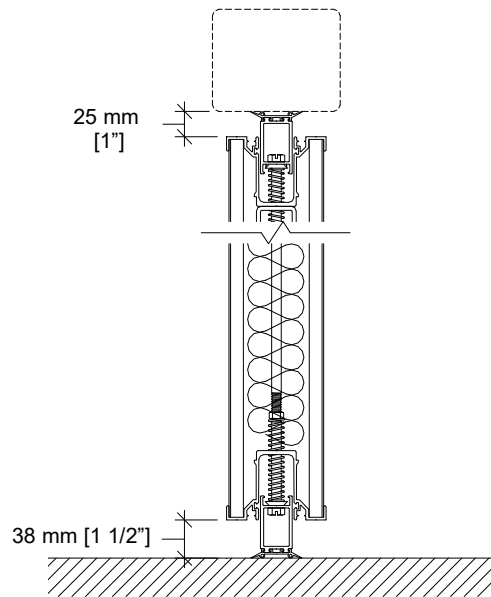

**Type AA**  
 Floor clearance : 38 mm [1 1/2"]  
 Operating tolerances :  
 +0 mm / -19 mm [+0" / -3/4"]

### Elevation

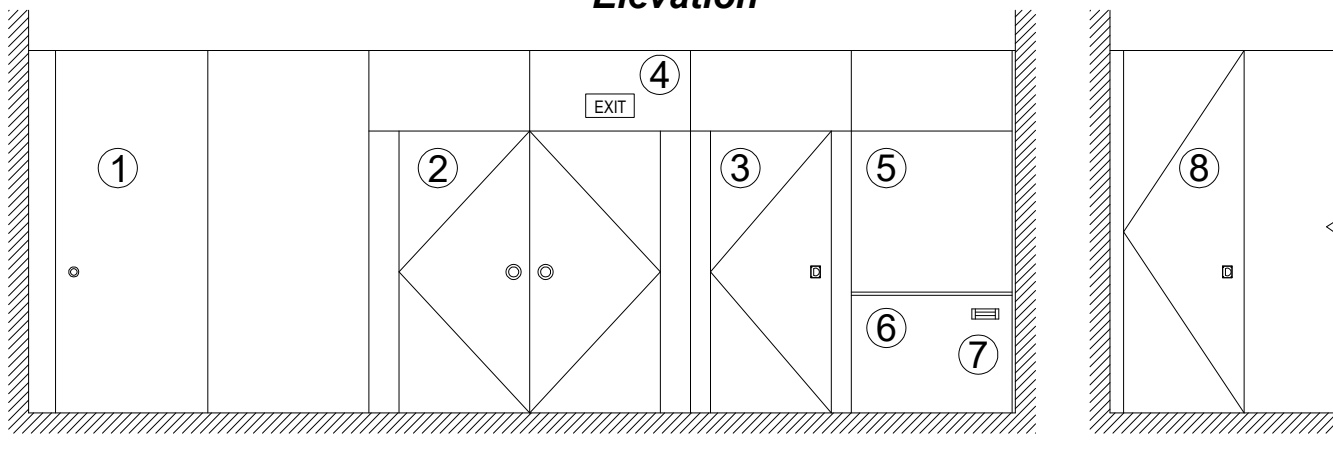

- |                               |                         |
|-------------------------------|-------------------------|
| 1- Telescopic closure panel   | 5- Work surface         |
| 2- Double pass doors          | 6- Chalk tray           |
| 3- Single pass door           | 7- Eraser box           |
| 4- Self-illuminated exit sign | 8- Hinged closure panel |

### Vertical Section

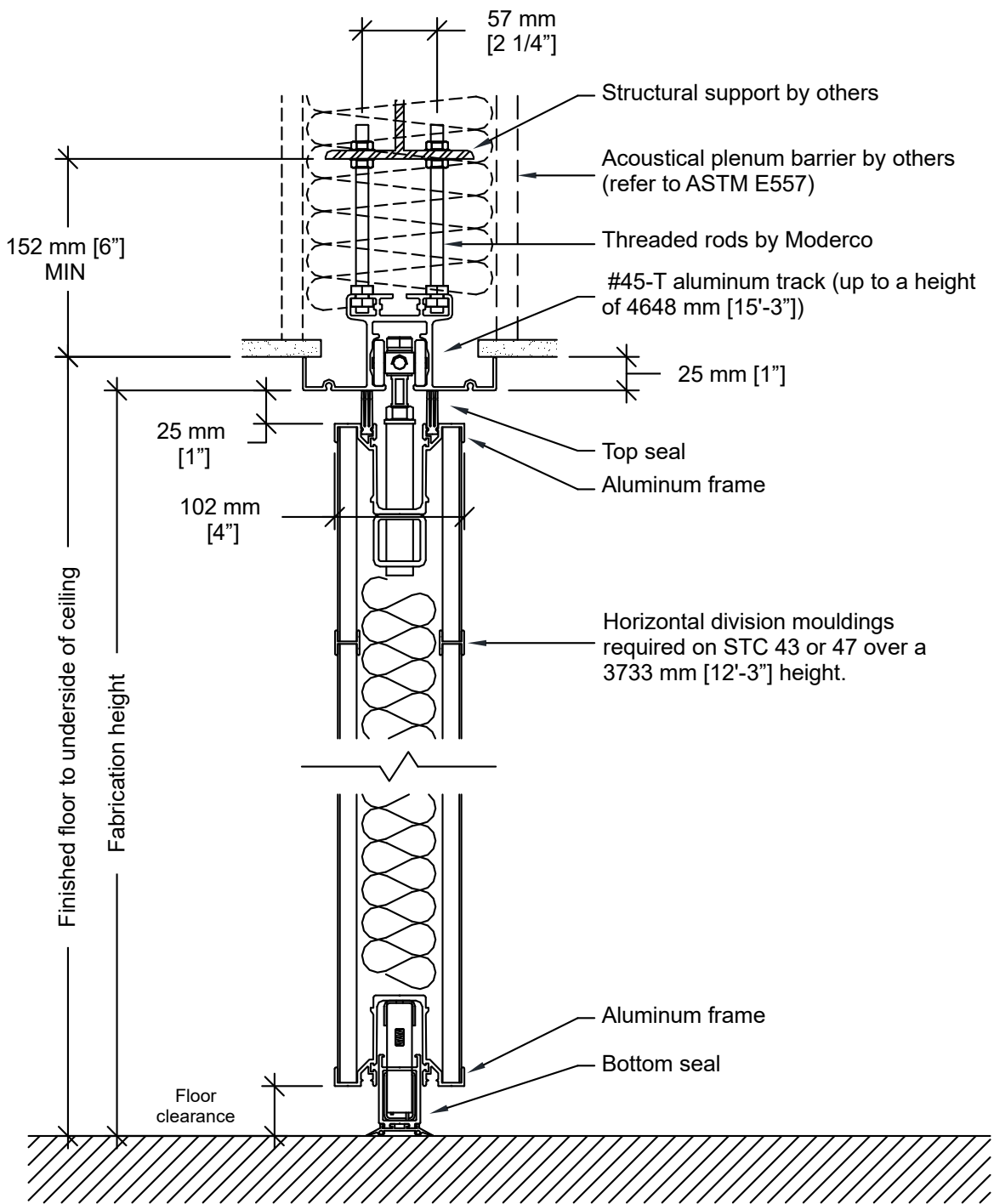

## Track Options

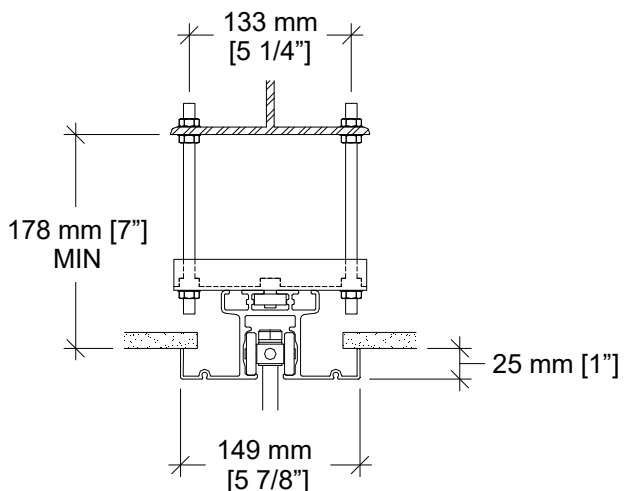

**#45-T track with optional hanger bracket**

Hanger bracket required for installations where the topmost nuts cannot be used for adjustment.

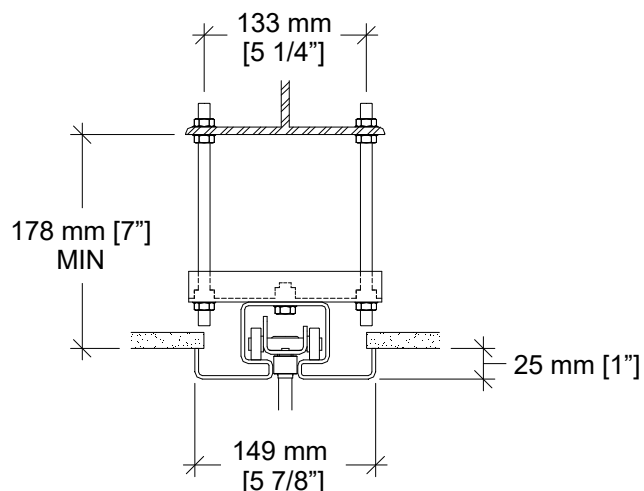

**#72 steel track with hanger bracket**

Optional for partitions up to 4648 mm [15'-3"].

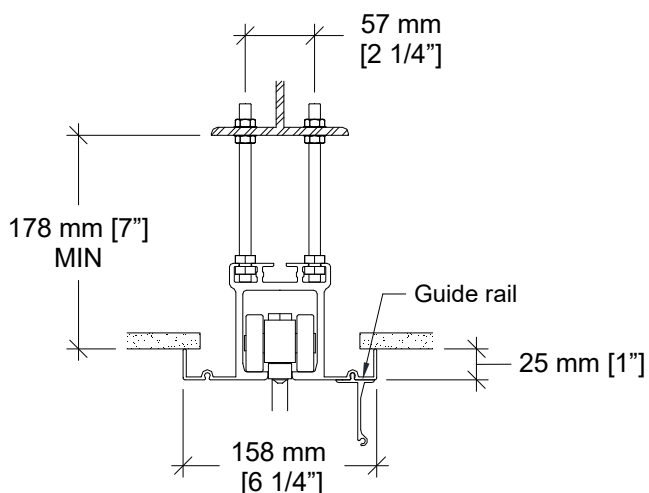

**#55-T aluminum track**

Standard for partitions from a height of 4648 mm [15'-3"] up to 6781 mm [22'-3"].

Optional for partitions up to 4648 mm [15'-3"].

Guide rail required for partitions over 4648 mm [15'-3"].

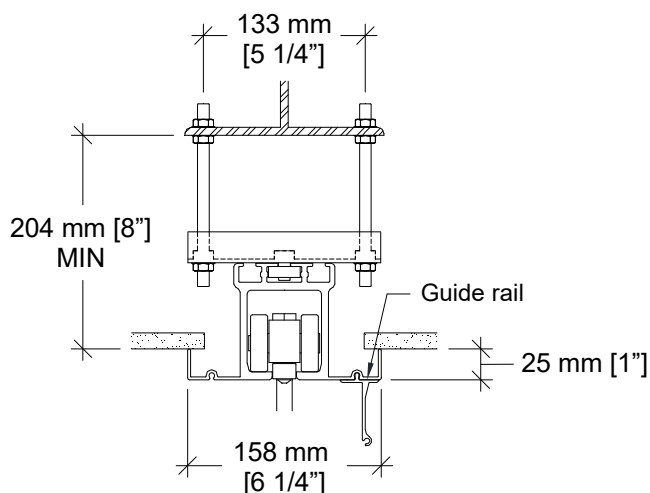

**#55-T aluminum track with optional hanger bracket**

**Plan Views**

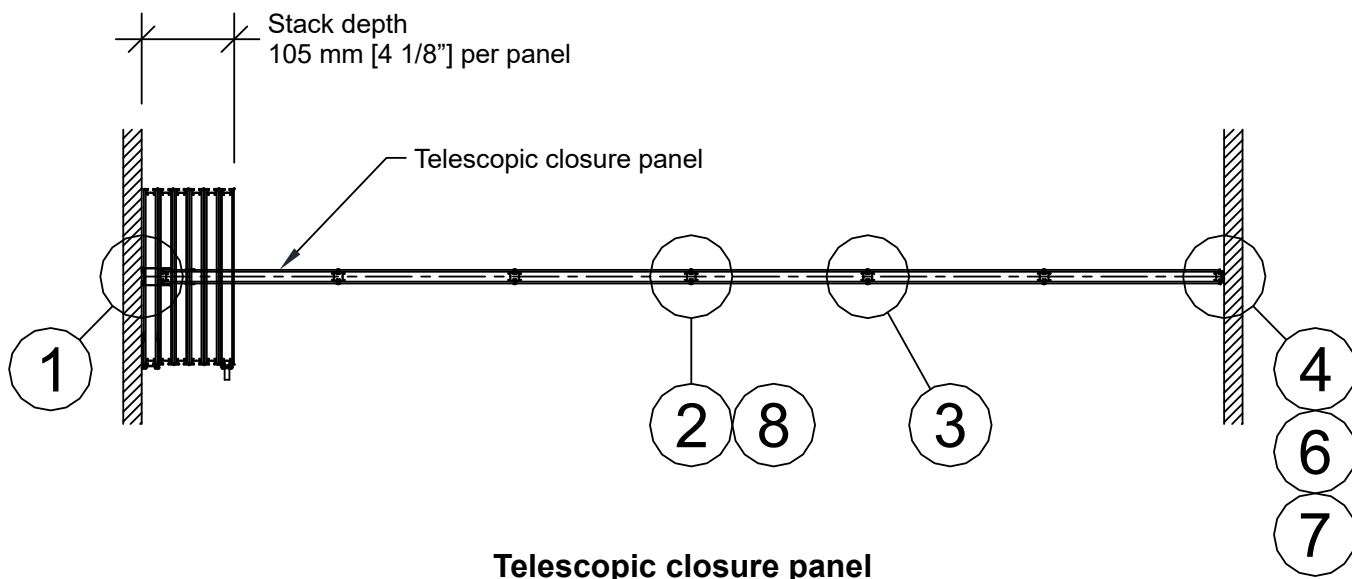

**Telescopic closure panel**

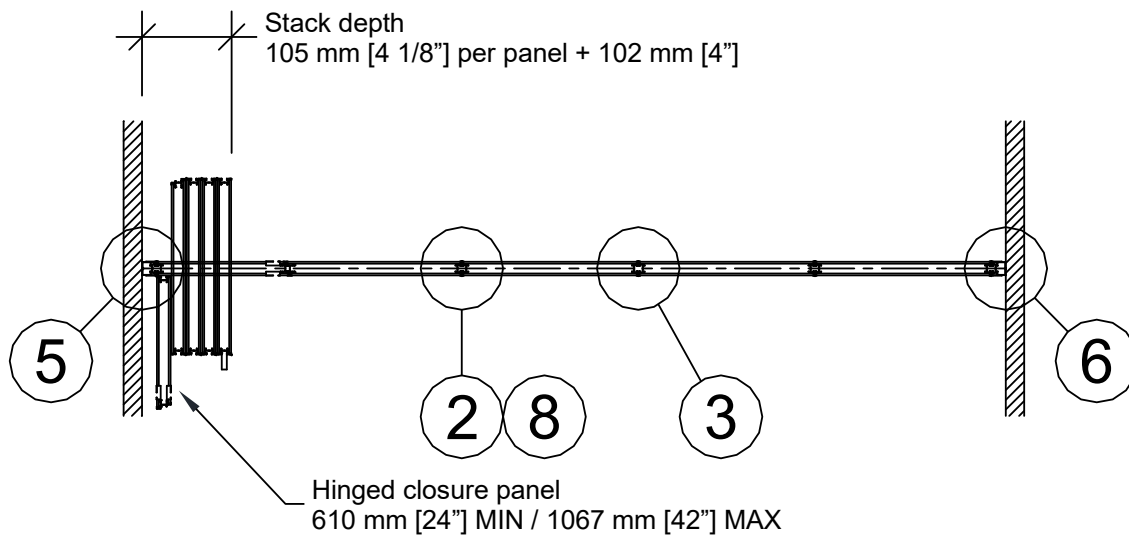

**Hinged closure panel**



### Horizontal Sections

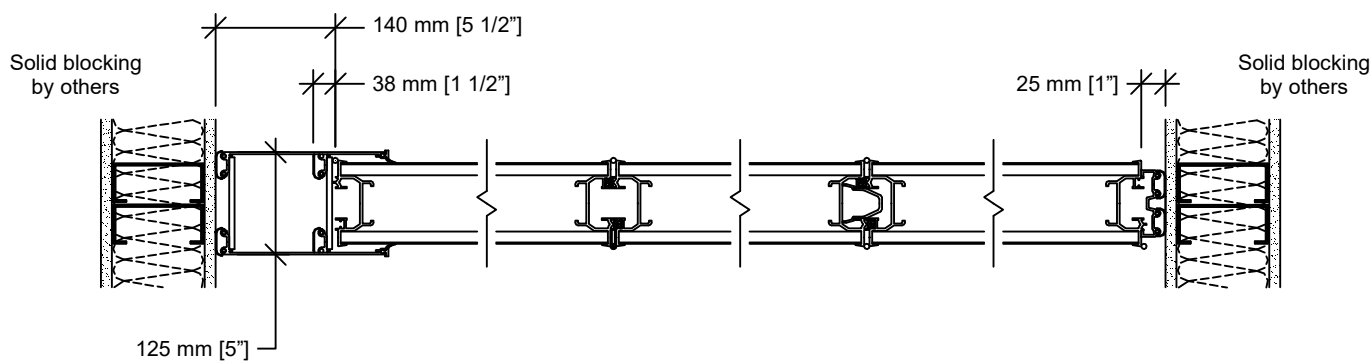

- ① Telescopic closure
- ② Hinged panel joint
- ③ Panel joint
- ④ Bulb seal

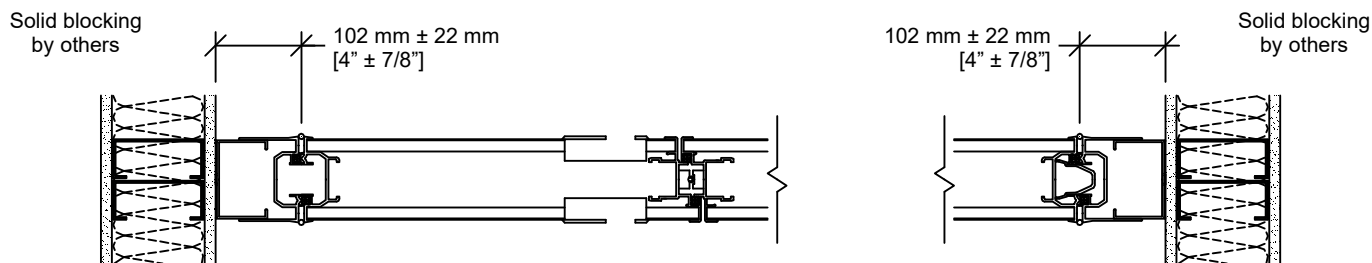

- ⑤ Hinged closure panel with recessed pulls and roller latch (optional)
- ⑥ Wall jamb (optional)

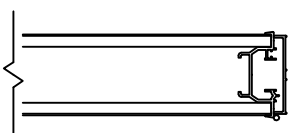

- ⑦ End cap (optional)

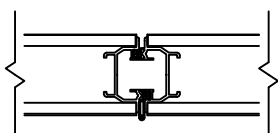

- ⑧ Panel joint with trimless vertical edges (optional)

### Typical Layouts

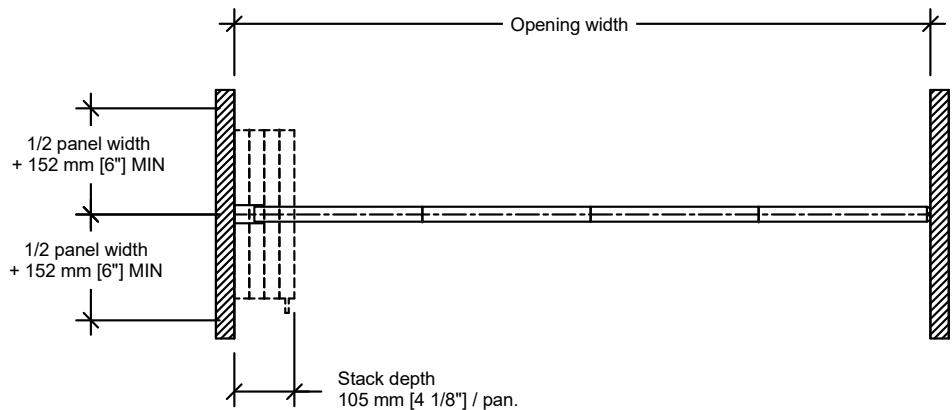

**Wall to wall – telescopic closure**

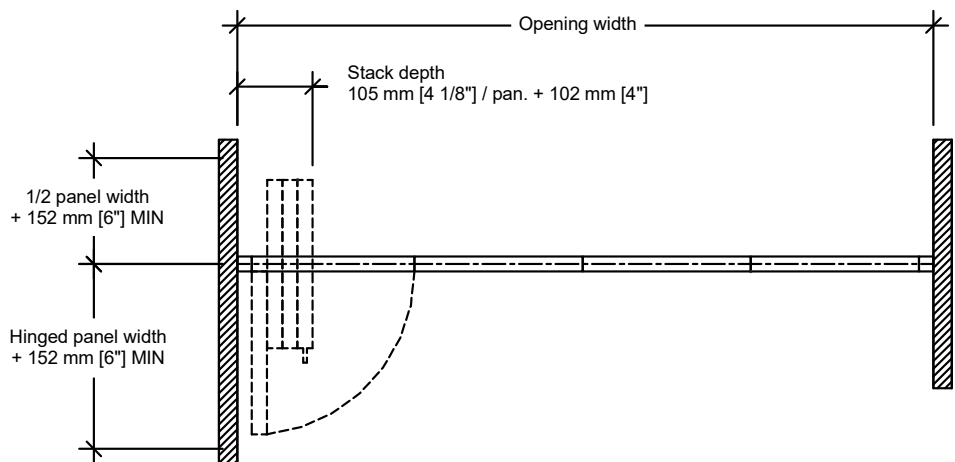

**Wall to wall – hinged closure**

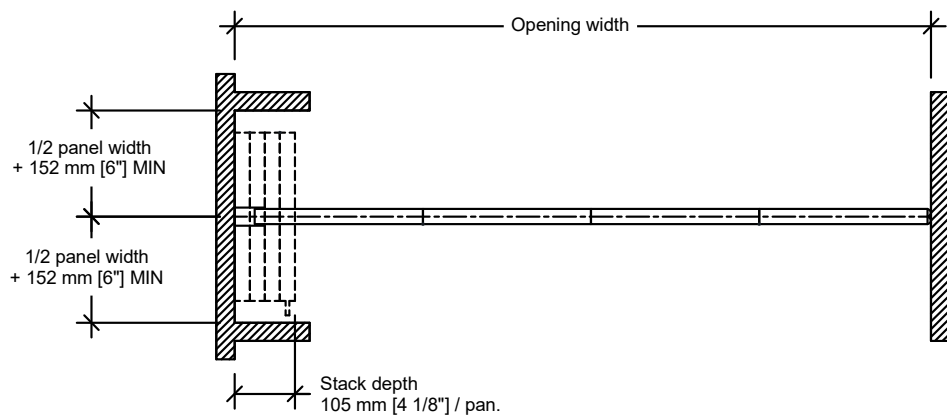

**Pocket**

**Typical Layouts (cont'd)**

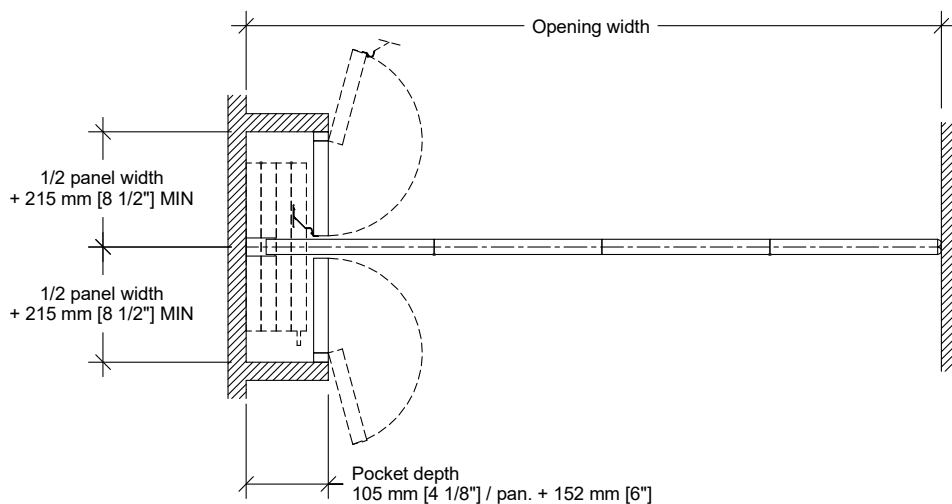

**Pocket and PN-83 non-acoustical pocket door  
(partition seals to back of pocket)**

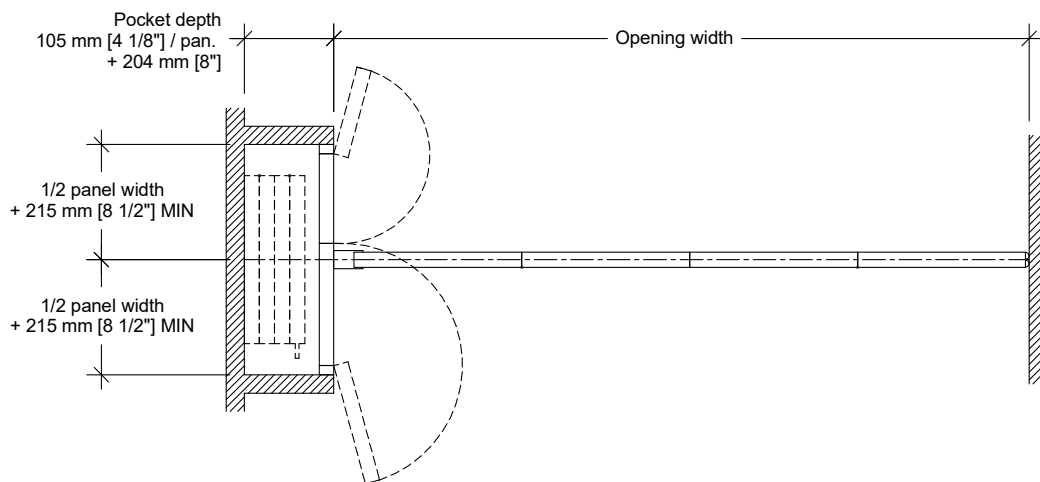

**Pocket and PA-82 acoustical pocket door  
(partition seals to face of pocket door)**