

Technical Data Sheet Signature 843-E

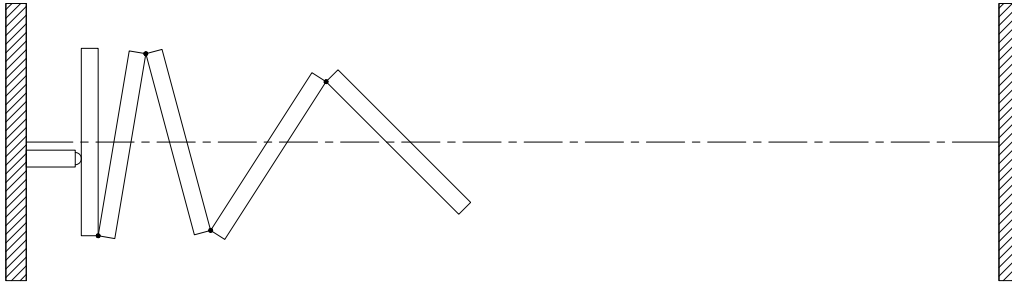

Features & Options

Standard Features

- Electrically-operated continuously-hinged movable partition.
- Driven by #35 roller chain.
- STC 43 or 47 with gypsum board faces.
- STC 49, 52, 53 and 55 with steel faces laminated to gypsum board.
- 102 mm [4"] nominal thickness. 1230 mm [48 1/2"] maximum width.
- Clear-anodized steel-reinforced aluminum frame.
- Protective trims on entire perimeter.
- Combination aluminum and vinyl tongue and groove vertical sound seals between panels.
- Final closure by lateral wall jamb.
- Low profile steel hinges.
- Clear-anodized 6063-T6 alloy aluminum track.
- Each panel supported by one 4-wheeled carrier with steel tires over hardened steel ball bearing wheels.
- Vinyl wallcovering.
- Type FF horizontal seals :
 - Fixed top and bottom sweeps
 - bottom seals provide a 50 mm [2"] floor clearance
 - standard for STC 43, 47, 49 and 52
 - optional for STC 53 and 55 panel core construction on bi-parting partitions
- Type FA horizontal seals:
 - Fixed top sweeps
 - Automatic retractable bottom seals set as panels are deployed
 - bottom seals provide a 50 mm [2"] floor clearance
 - standard for STC 53 and 55
 - optional for STC 43, 47, 49 and 52
- Maximum height: 6780 mm [22'-3"]
Maximum length: 30480 mm [100'-0"]
- UL/ULC listed drive unit with NEMA-1 motor enclosure and controls and control enclosure conform to ANSI/NEMA ICS1, ICS 2 and ICS 6.
- 1.5 hp / 120 V / 1 ph / 60 Hz
- Travel controlled by limit switches.
- Operation by two simultaneously-activated key switches located on each side of the partition.
- Emergency release mechanism for manual operation during power outage.
- STC 49, 52, 53 or 55 with gypsum board faces and steel backing.

Optional Features and Accessories

- Powder-coated protective trims and/or track.
- Upgraded wallcoverings: fabric, vertically-ribbed carpet, plastic laminate, full-height marker board, wood veneer, custom finishes.
- Owner-supplied wallcovering (approval required).
- ADA-compliant pass door with flush pulls and roller latch.
2590 mm [8'-6"] ceiling height required with FF seals.
2945 mm [9'-8"] ceiling height required with FA seals.
- Door options:
 - concealed automatic closer
 - window frame
 - door viewer
 - self-luminous "Running Man" exit sign with green faceplate (standard outside USA, optional in USA)
 - photoluminescent "EXIT" sign with red faceplate (standard in USA, optional elsewhere)
 - photoluminescent "EXIT" sign with green faceplate (optional)
 - self-luminous "EXIT" sign with red faceplate (optional)
 - self-luminous "EXIT" sign with green faceplate (optional)
 - deadbolt lock (not available with exit sign)
- Inset standard or porcelain white marker boards, chalk boards, natural cork tack boards, eraser boxes, chalk trays.
- 3-section pocket door fitted with limit switches to prevent operation of the partition until the pocket door is fully opened.
- Trimless vertical edges. The following restrictions apply:
 - STC 49, 52, 53 and 55 with steel faces laminated to gypsum board only.
 - Type FA horizontal seals only.
 - Maximum overall size: 90 m² [1000 sqft] (in addition to standard maximum height and length)
 - Vinyl, fabric, vertically-ribbed carpet wallcovering or full-height standard marker board only.
 - Owner-supplied wallcovering (approval required).
 - Trimless standard white boards only. Porcelain white boards not available.

Horizontal Seals

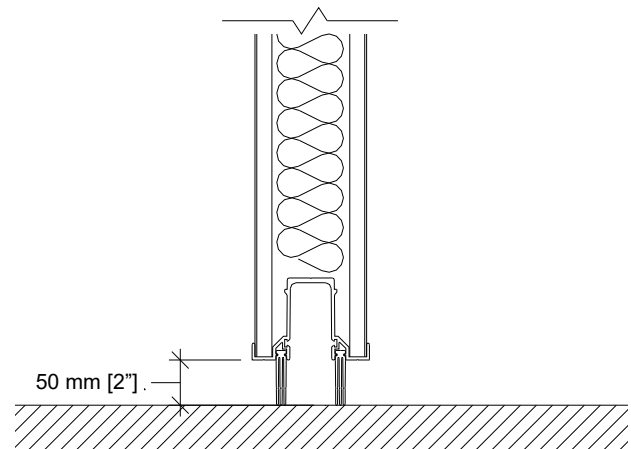

Type FF

Floor clearance : 50 mm [2"]
Operating tolerances :
+0 mm / -38 mm [+0" / -1 1/2"]

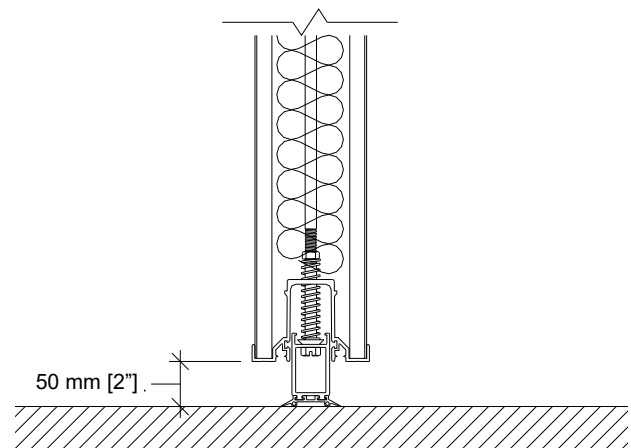

Type FA

Floor clearance : 50 mm [2"]
Operating tolerances :
+0 mm / -38 mm [+0" / -1 1/2"]

Vertical Section

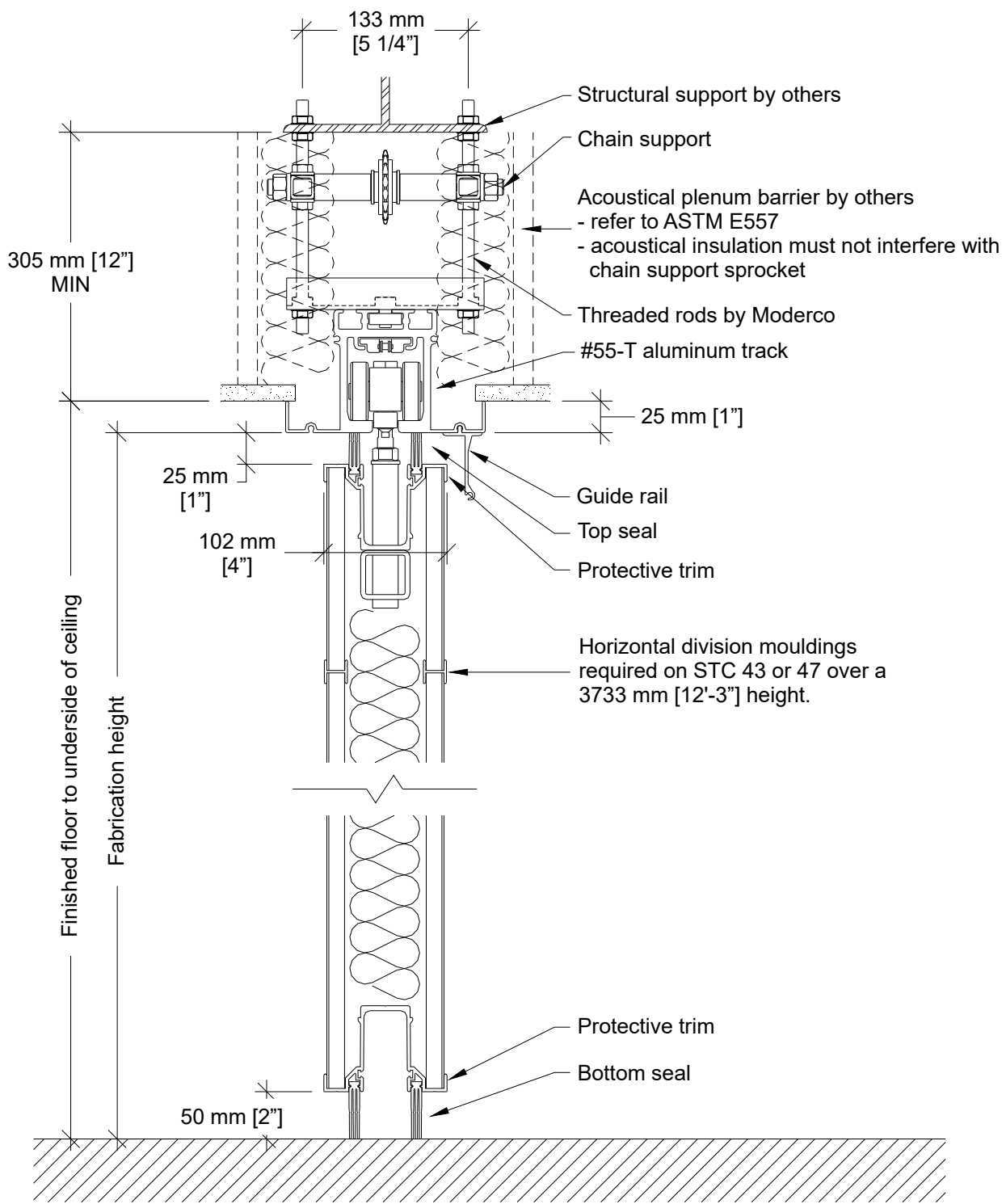

Plan Views

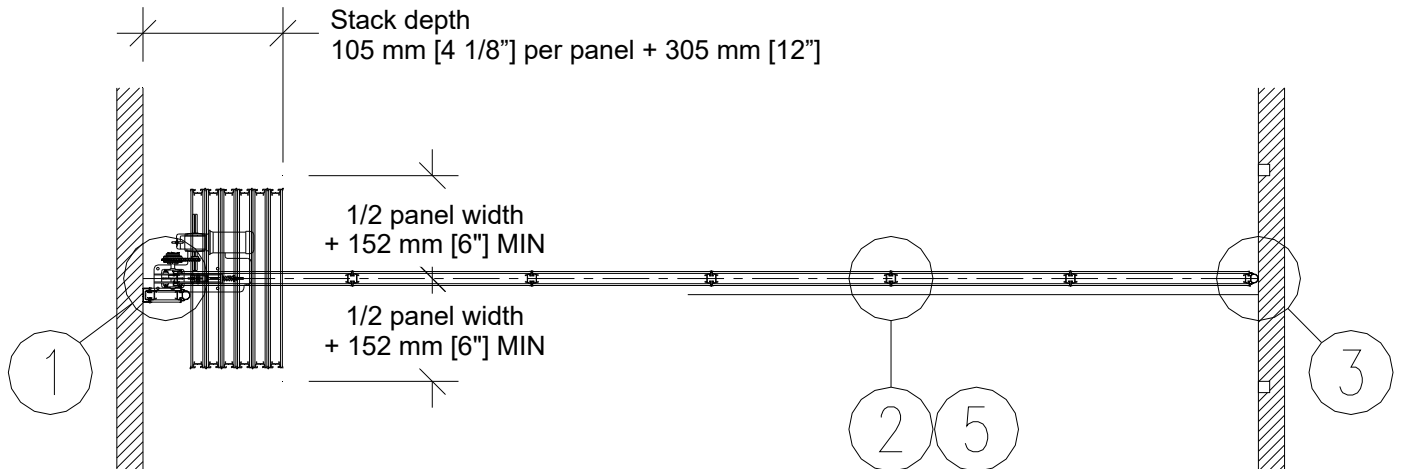

Wall to wall

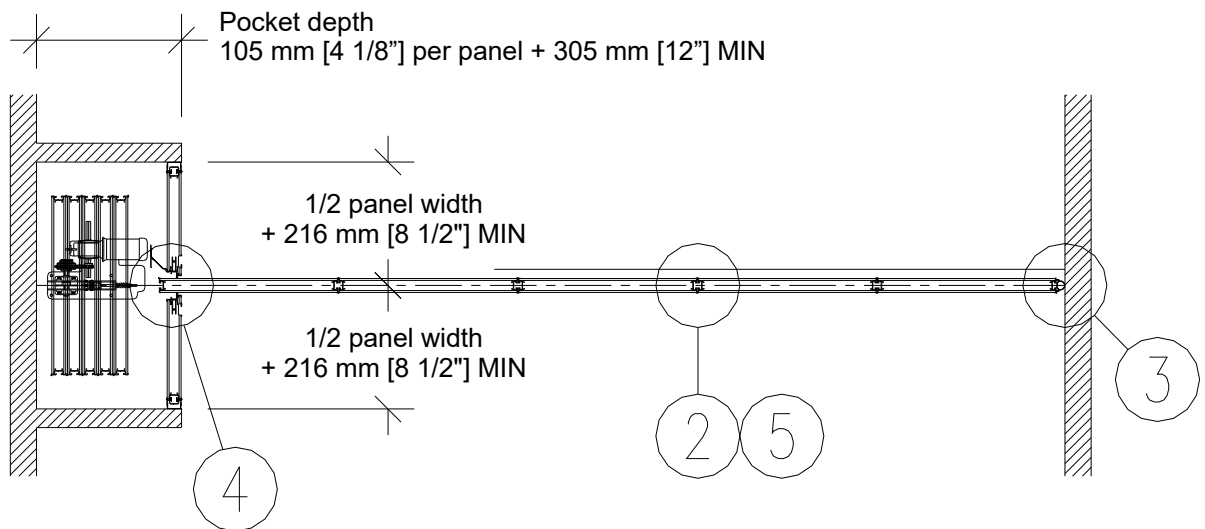

Wall to pocket with PA-83 acoustical pocket door

Horizontal Section

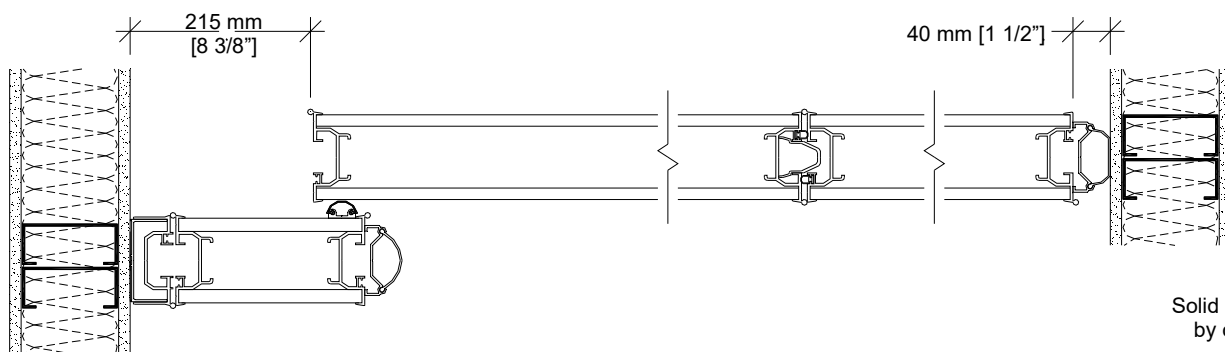

Solid blocking by others



1 Side jamb closure



2 Panel joint



3 Bulb seal

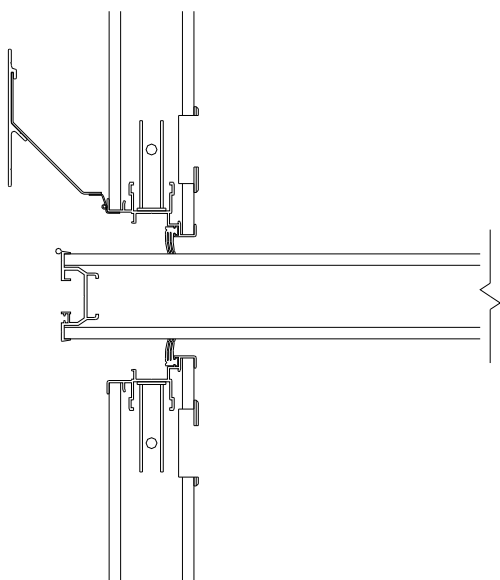

4 Closure at pocket door (optional)

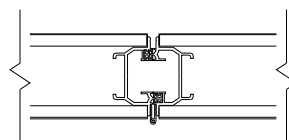

5 Panel joint with trimless vertical edges (optional)

Elevation

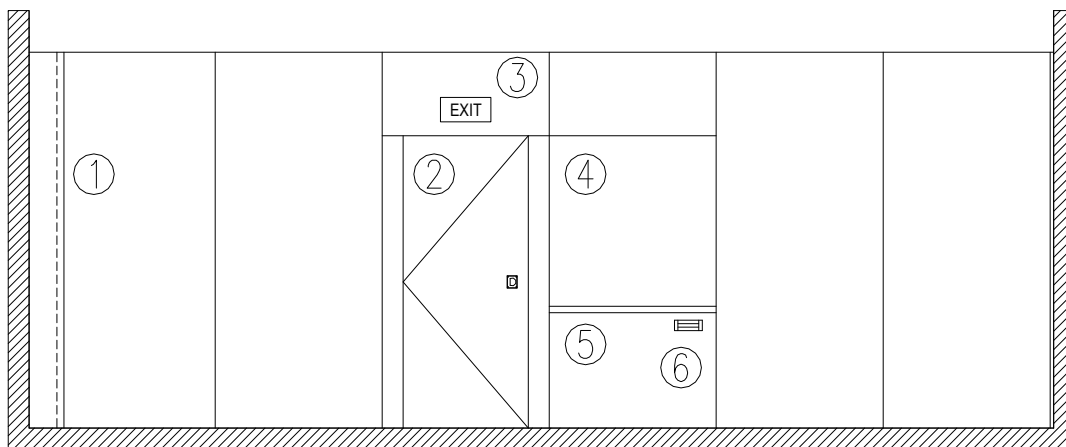

- | | |
|-------------------------------|-----------------|
| 1- Closure panel | 4- Work surface |
| 2- Single pass door | 5- Chalk tray |
| 3- Self-illuminated exit sign | 6- Eraser box |

Optional Bi-parting layouts

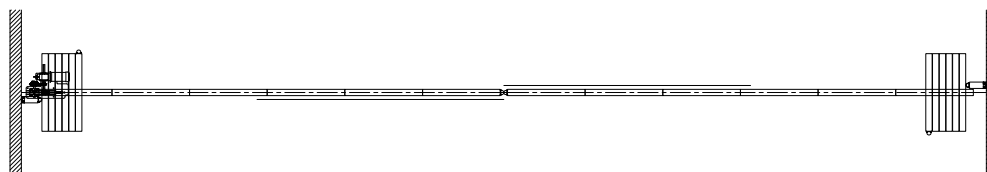

Wall to wall

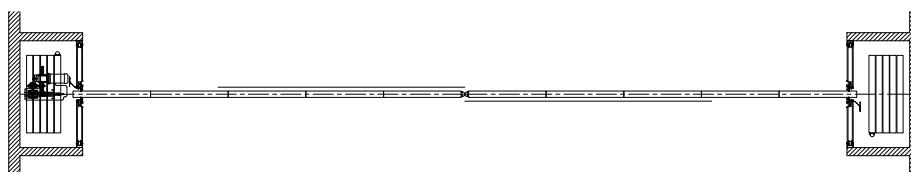

Pocket to pocket with PA-83 acoustical pocket doors

Drive Unit

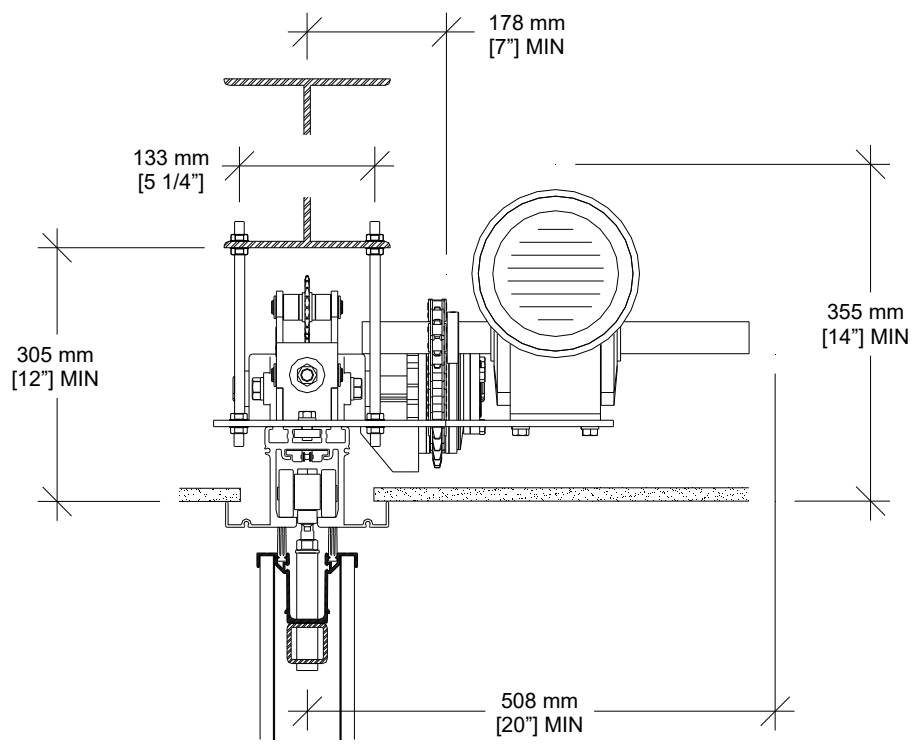

Optional Safety Devices

