

Technical Data Sheet Vision 121



Features & Options

Standard Features

- Manually-operated individual-panel glass movable partition.
- 35 mm [1 3/8"] nominal thickness. Up to 1220 mm [48"] width.
- Clear 12 mm [1/2"] tempered glass faces with polished vertical edges.
- Clear anodized aluminum horizontal mouldings with brush seals.
- Each panel fitted with a foot bolt to stabilize the partition.
- Clear anodized 6063-T6 alloy aluminum track.
- Each panel supported by two dual horizontal wheel carrier with nylon tires over hardened precision ground steel ball bearing wheels.
- Maximum height : 3658 mm [12'-0"].

Optional Features and Accessories

- Powder-coated frame and/or track.
- Glass finishes : stained, colored, acid washed, frosted, etc.
- 11 ga. steel track with programmable switches, painted white.
- Floor bolt for last movable panel fitted with :
 - keyed locks both sides
 - keyed lock and thumb turn
- Final closure by ADA-compliant pivot panel.
- Pivot panel accessories :
 - keyed locks both sides
 - keyed lock and thumb turn

Vertical Section

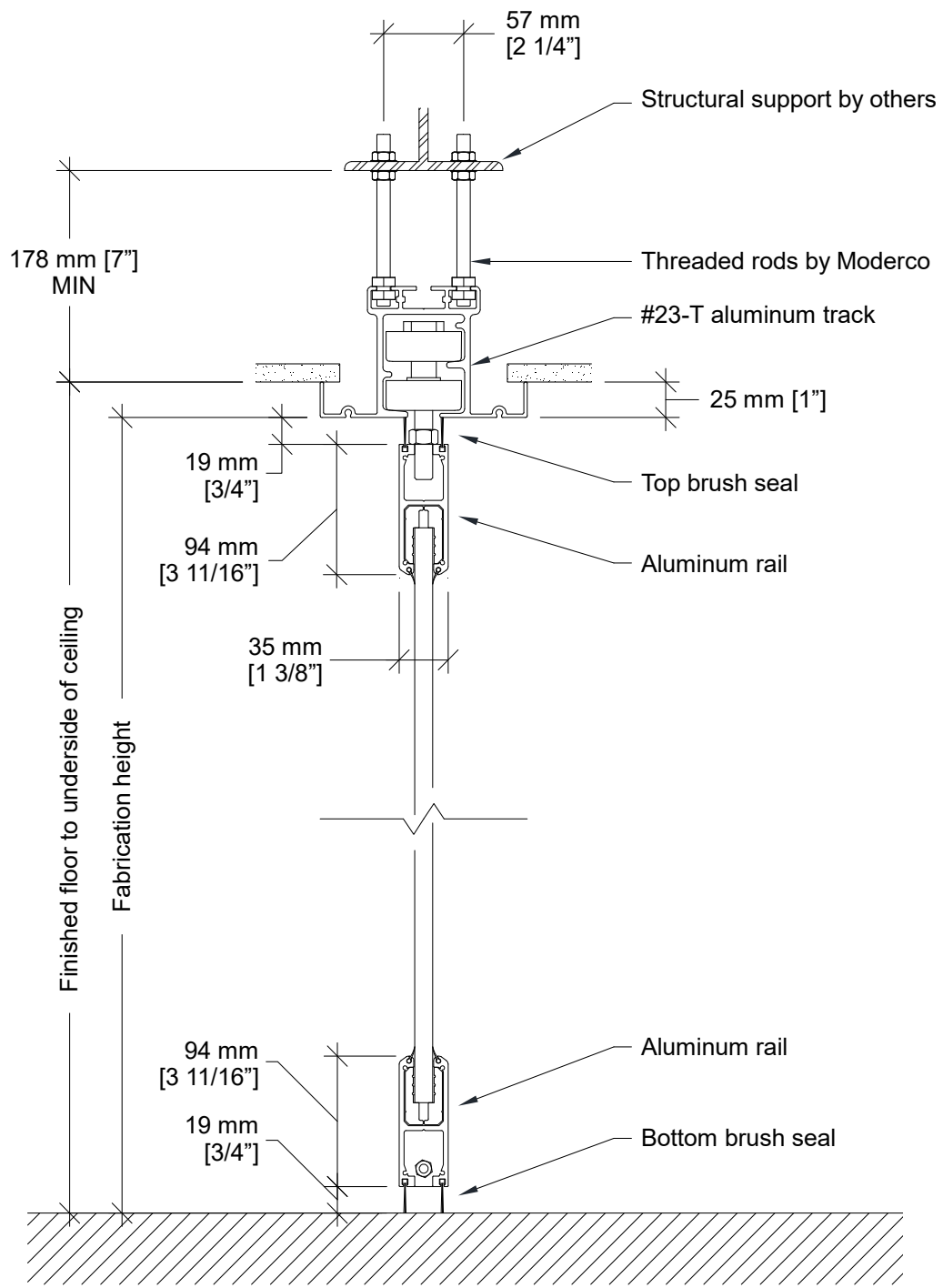

Track Options

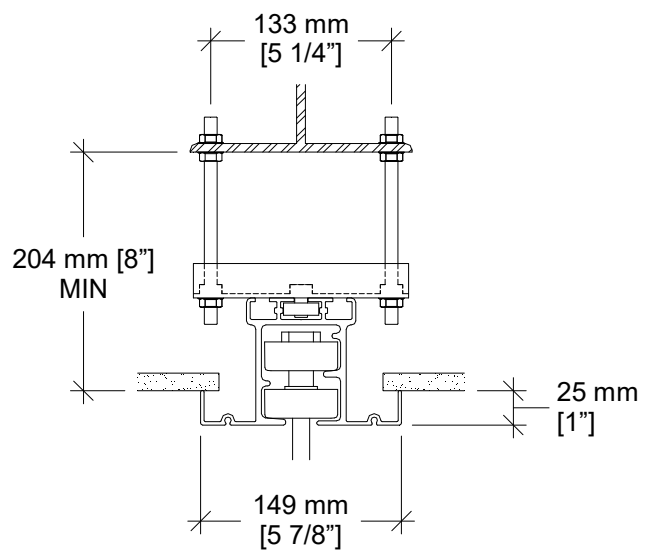

Optional Hanger Bracket

Required for installations where the topmost nuts cannot be used for adjustment.

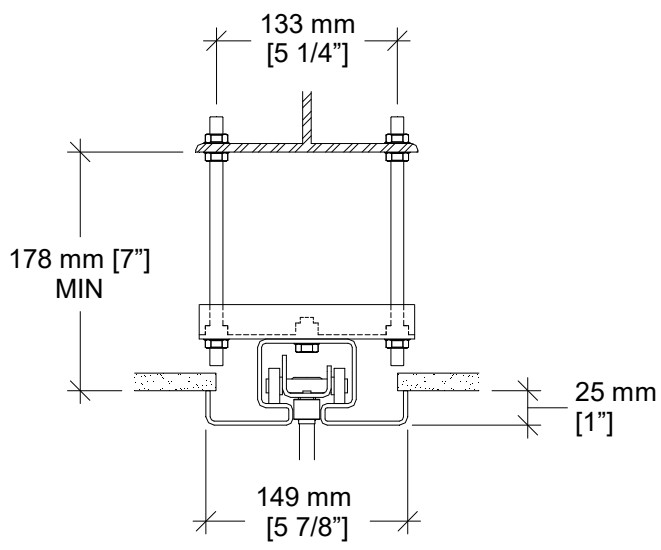

#72 steel track with hanger bracket

Programmable switches.
Requires pivot panel closure.

Elevation

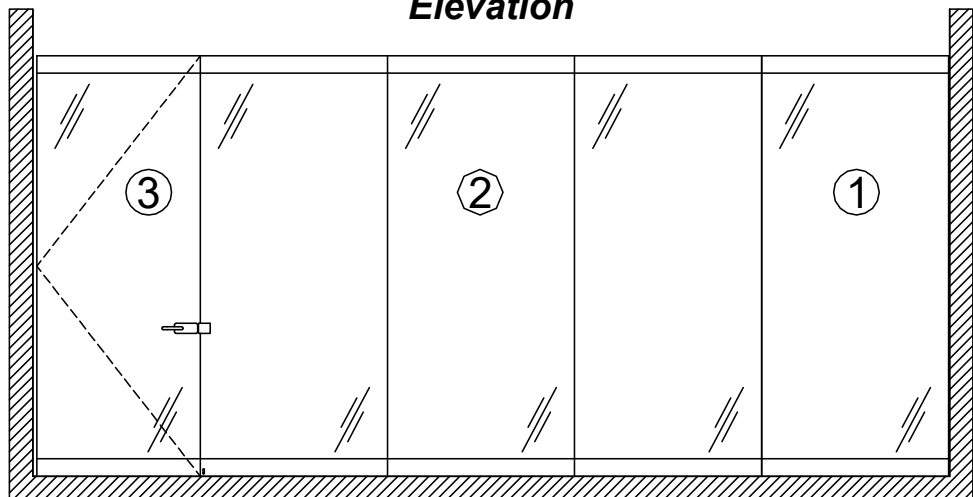

- 1- Lead panel
- 2- Intermediate panel
- 3- Optional pivot closure panel

Plan Views

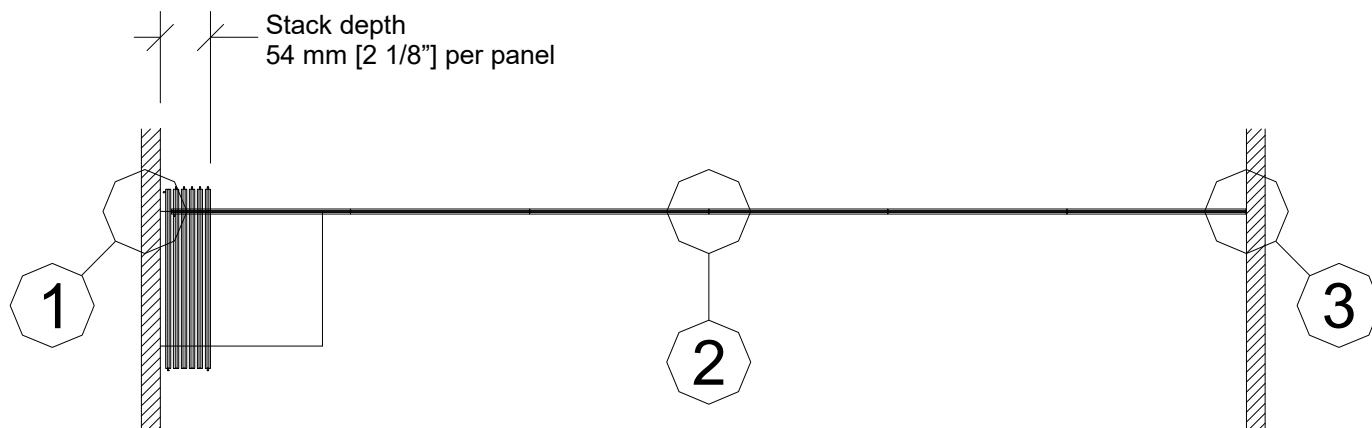

Wall to wall layout

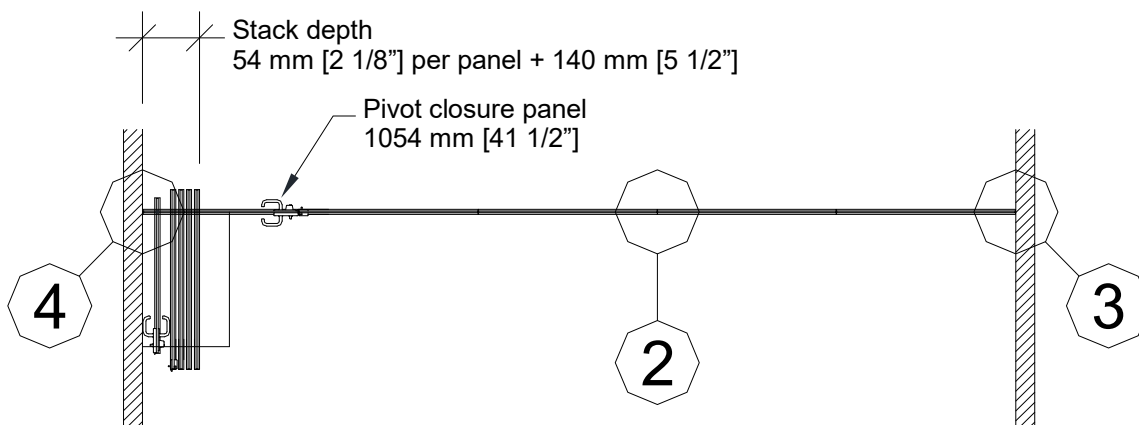

Pivot closure panel

Horizontal Sections

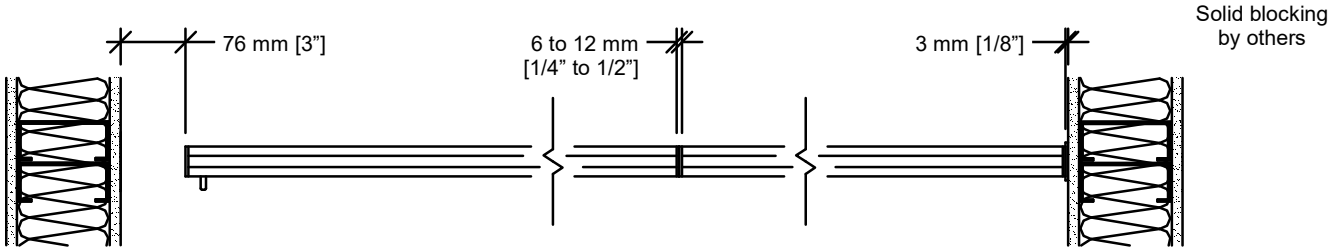

1 Trail end

2 Panel joint

3 Lead end

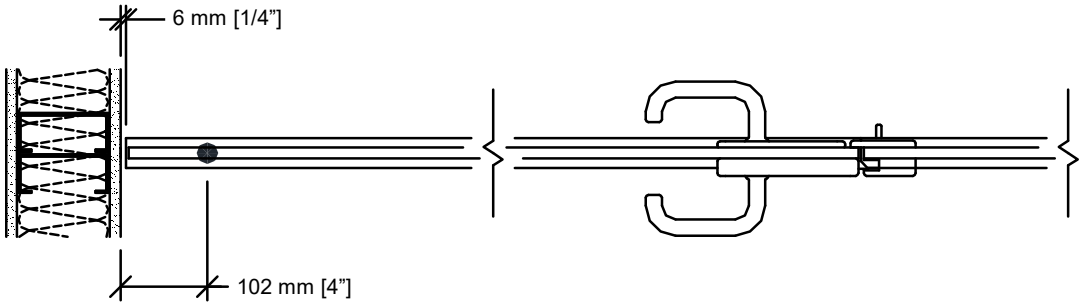

4 Optional pivot closure panel

Floor Bolts

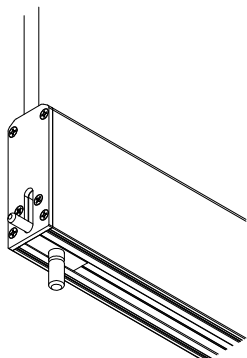

Edge-activated floor bolt.

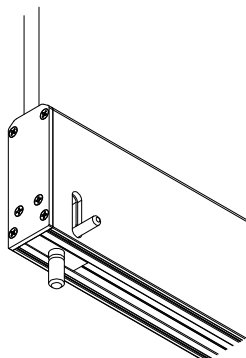

Face-activated floor bolt.

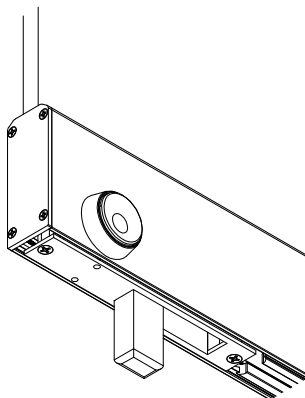

Face-activated floor lock with 2 key cylinders.

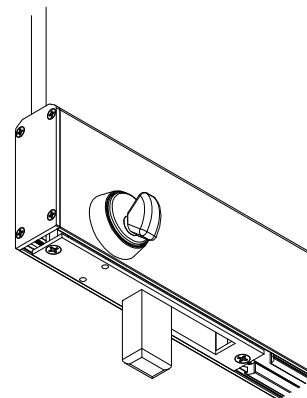

Face-activated floor lock with 1 key cylinder and 1 thumb turn.

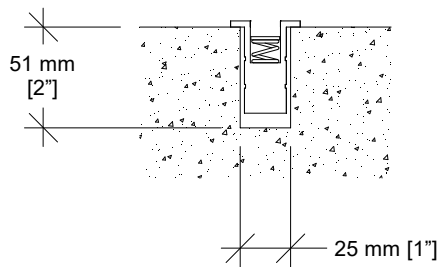
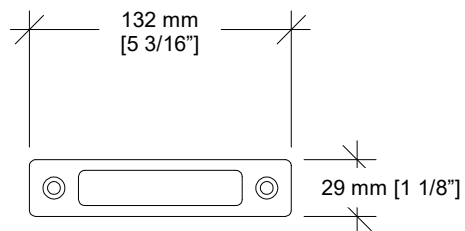
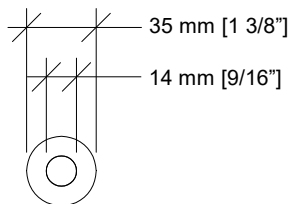

Dust-proof strike for floor bolt

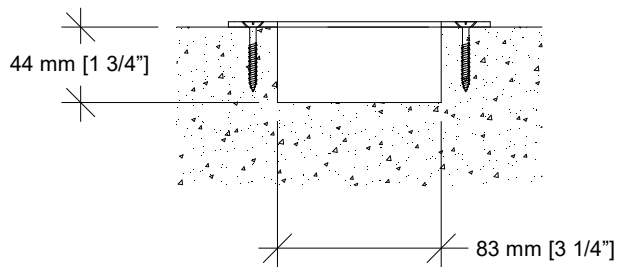

Strike for floor lock

Typical Layouts - #23-T Track

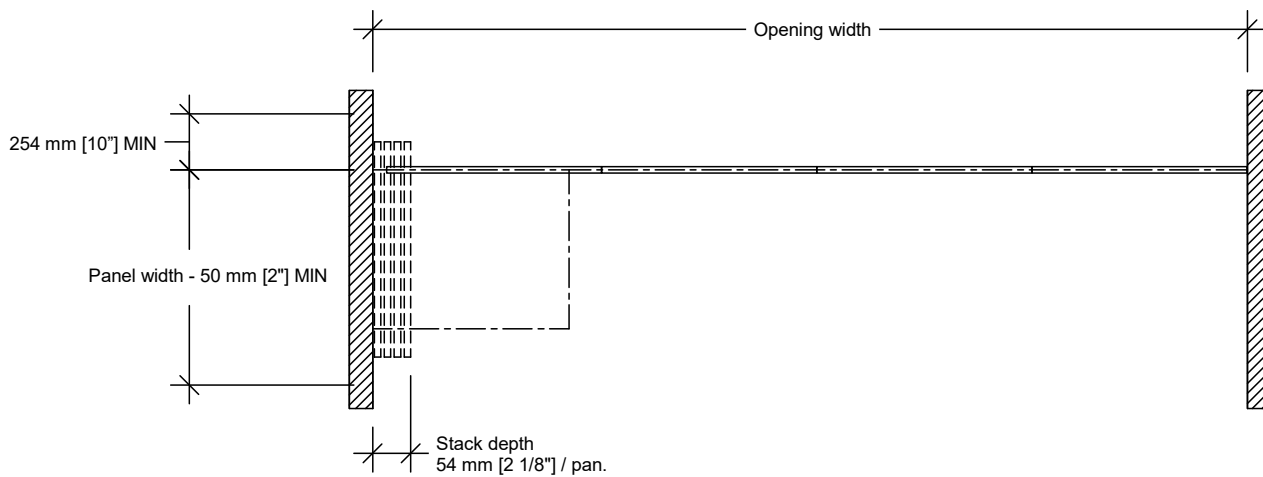

Wall to wall Side Stack

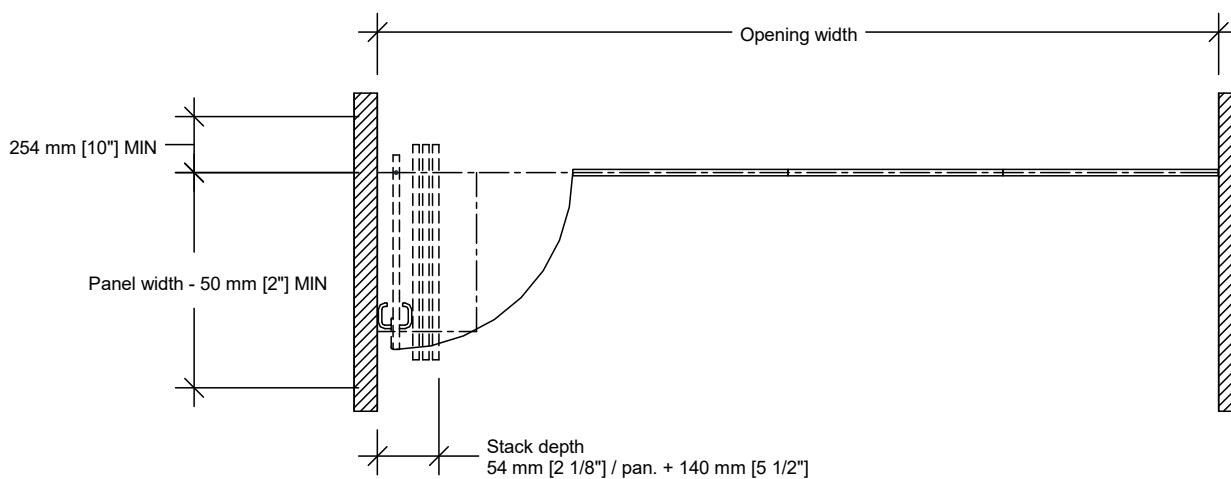

Wall to wall Side Stack – pivot closure

Typical Layouts - #23-T Track (cont'd)

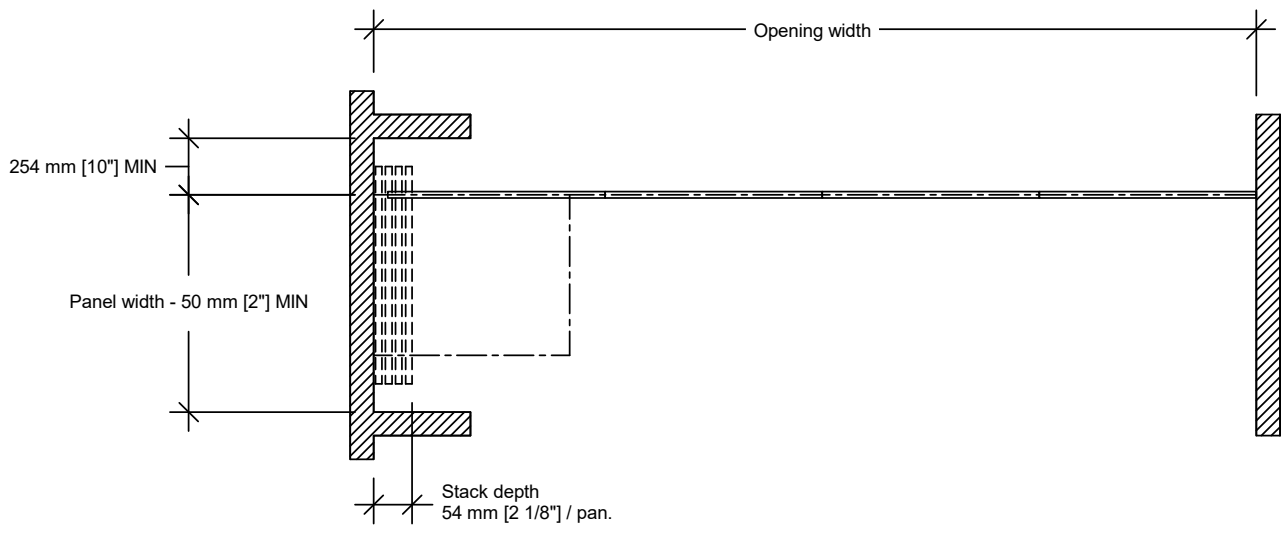

Pocket

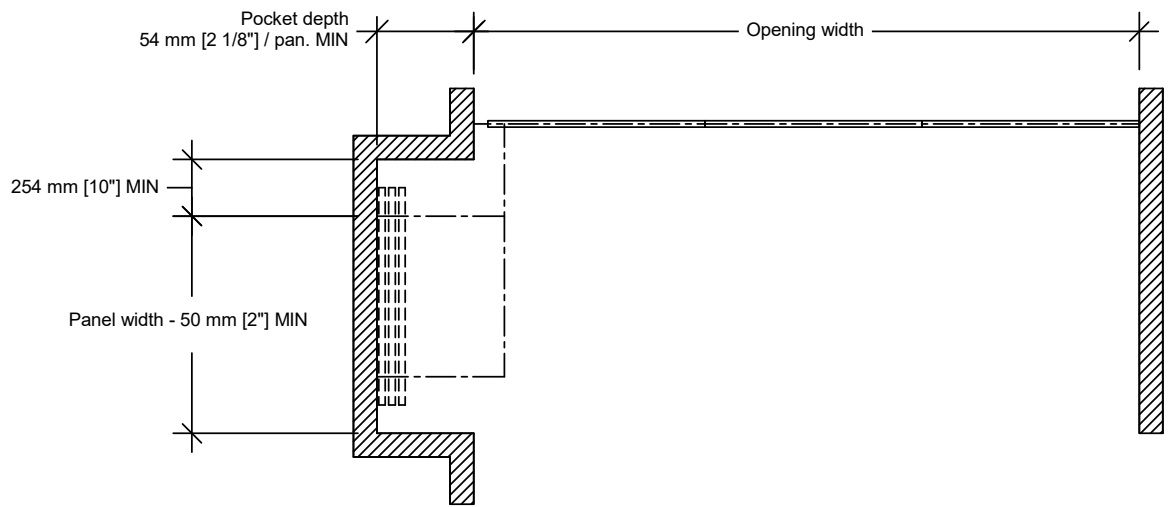

Remote Stack



Typical Layout - #72 Track

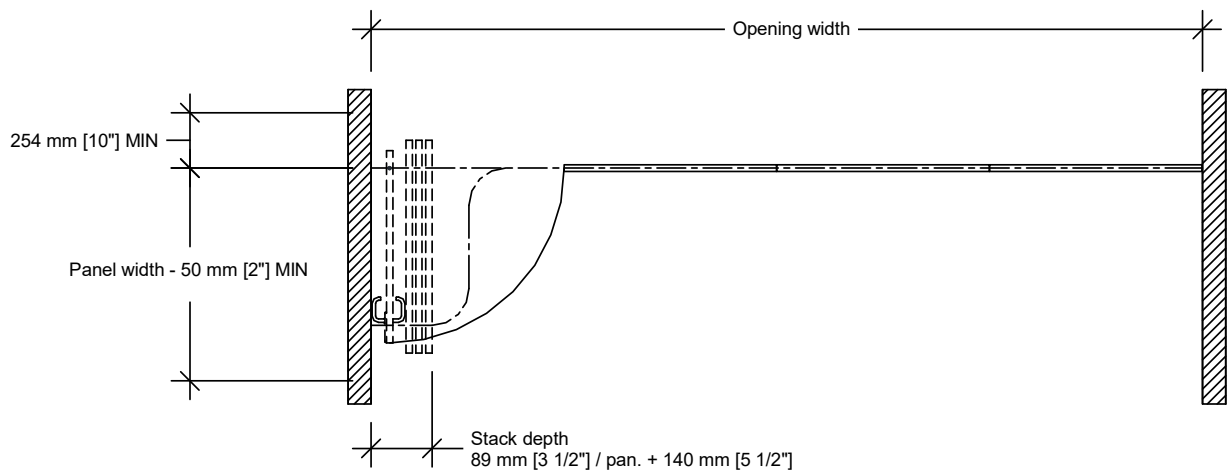

Wall to wall Side Stack – pivot closure